



# BOSCH

Installation Manual

## MIDDLE STATIC PRESSURE DUCT TYPE AIR CONDITIONER **Climate 5000 SCI**

CL5000SCI

18-2 DCT/OU- OUE

24-2 DCT/OU- OUE

30-2 DCT/OU- OUE

36-2 DCT/OU- OUE

42-2 DCT/OU- OUE

48-2 DCT/OU- OUE

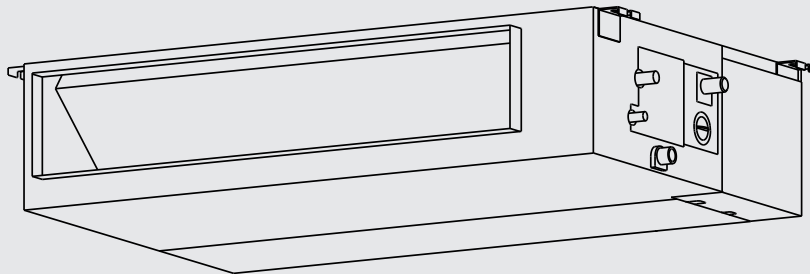

---

**Table of Content**

---

<b>1</b>	<b>Accessories.....</b>	<b>3</b>
<b>2</b>	<b>Safety Precautions .....</b>	<b>4</b>
<b>3</b>	<b>Installation Overview .....</b>	<b>6</b>
<b>4</b>	<b>Indoor Unit Installation .....</b>	<b>7</b>
4.1	Indoor Unit Parts .....	7
4.2	Indoor Unit Installation Instructions .....	7
<b>5</b>	<b>Outdoor Unit Installation.....</b>	<b>11</b>
5.1	Outdoor Unit Installation Instructions .....	11
5.2	Drain Joint Installation.....	12
5.3	Notes On Drilling a Hole in the Wall .....	13
<b>6</b>	<b>Drainpipe Installation .....</b>	<b>13</b>
<b>7</b>	<b>Refrigerant Piping Connection .....</b>	<b>15</b>
7.1	Notes On Pipe Length and Elevation.....	15
7.2	Refrigerant Piping Connection Instructions.....	16
<b>8</b>	<b>Wiring.....</b>	<b>19</b>
8.1	Outdoor Unit Wiring .....	19
8.2	Indoor Unit Wiring.....	20
8.3	Power Specifications.....	21
<b>9</b>	<b>Air Evacuation .....</b>	<b>22</b>
9.1	Evacuation Instructions .....	22
9.2	Note On Adding Refrigerant.....	22
<b>10</b>	<b>Test Run.....</b>	<b>23</b>
<b>11</b>	<b>European Disposal Guidelines .....</b>	<b>24</b>
<b>12</b>	<b>Information on Servicing.....</b>	<b>24</b>

**CAUTION**

Risk of fire (for R32 refrigerant)

## 1 Accessories

The air conditioning system comes with the following accessories. Use all of the installation parts and accessories to install the air conditioner. Improper installation may result in water leakage, electrical shock and fire, or equipment failure.









	Name	Shape	Quantity
<b>Tubing &amp; Fittings</b>	Soundproof / insulation sheath		2
	Seal sponge (some models)		1
	Orifice (some models)		1
<b>Drainpipe Fittings (for cooling &amp; heating)</b>	Drain joint (some models)		1
	Seal ring (some models)		1
<b>EMC Magnetic Ring (some models)</b>	Magnetic ring (wrap the electric wires S1 & S2 ( P & Q & E ) around the magnetic ring twice)		1
	Magnetic ring (Hitch the connective cable between the indoor unit and outdoor unit after installation.)		1
<b>Others</b>	Owner's manual		1
	Installation manual		1
	Transfer connector (Ø12.7-Ø15.9) (Packed with the indoor unit) NOTE: Pipe size may differ from appliance to appliance. To meet different pipe size requirements, sometimes the pipe connections need a transfer connector installed on the outdoor unit.		1 (on some models)
	Transfer connector (Ø6.35-Ø9.52) (Packed with the indoor unit) NOTE: Pipe size may differ from appliance to appliance. To meet different pipe size requirements, sometimes the pipe connections need a transfer connector installed on the outdoor unit.		1 (on some models)
	Transfer connector (Ø9.52-Ø12.7) (Packed with the indoor unit, used for multi-type models only) NOTE: Pipe size may differ from appliance to appliance. To meet different pipe size requirements, sometimes the pipe connections need a transfer connector installed on the outdoor unit.		1 (on some models)
	Connecting wire for display (2 m)		1 (on some models)
	Cord protection rubber ring		1 (on some models)

Table 1.

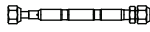
### Optional accessories

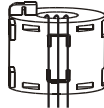
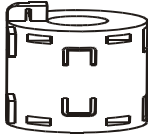
- There are two types of remote controls: wired and wireless. Select a remote controller based on customer preferences and requirements and install in an appropriate place. Refer to catalogues and technical literature for guidance on selecting a suitable remote controller.

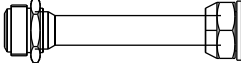
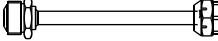
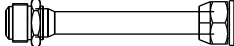
## 2 Safety Precautions

### Read Safety Precautions Before Installation

**Incorrect installation due to ignoring instructions can cause serious damage or injury.**

The seriousness of potential damage or injuries is classified as either a **WARNING** or **CAUTION**.

**WARNING**

Failure to observe a warning may result in death. The appliance must be installed in accordance with national regulations.

**CAUTION**

Failure to observe a caution may result in injury or equipment damage.

**WARNING**

- The appliance must be stored in a room without continuously operating ignition sources (for example: open flames, an operating gas appliance or an operating electric heater).
- Do not pierce or burn.
- The appliance must be stored so as to prevent mechanical damage from occurring.
- Be aware that the refrigerants may be odourless.
- Compliance with national regulations must be observed.
- Keep ventilation openings clear of obstruction.
- Warning: The appliance must be stored in a well-ventilated area where the room size corresponds to the room area as specified for operation.
- Any person who is involved with working on or breaking into a refrigerant circuit should hold a current valid certificate from an industry-accredited assessment authority which authorises their competence to handle refrigerants safely in accordance with an industry recognised assessment specification.
- Servicing must only be performed by qualified personnel. Maintenance and repair requiring the assistance of other qualified personnel must be carried out under the supervision of a person competent in the use of flammable refrigerants.
- Appliance must be stored in a well-ventilated area where the room size corresponds to the room area as specified for operation.
- Appliance must be stored in a room without continuously operating heat source (for example an operating gas appliance) and ignition sources (for example an operating electric heater).
- Appliance must be installed, operated and stored in a room with a floor area larger than X m<sup>2</sup>, installation of pipework must be kept to a minimum of X m<sup>2</sup> (Please see the following form). The appliance must not be installed in an unventilated space, if that space is smaller than X m<sup>2</sup> (Please see the following form). Spaces with refrigerant pipes must comply with national gas regulations.
- The appliance must be stored in a room without continuously operating ignition sources (for example: open flames, an operating gas appliance or an operating electric heater).
- Do not pierce or burn.
- The appliance must be stored so as to prevent mechanical damage from occurring.

- Be aware that the refrigerants may be odourless.
- Compliance with national gas regulations must be observed.
- Keep ventilation openings clear of obstruction.
- Warning: The appliance must be stored in a well-ventilated area where the room size corresponds to the room area as specified for operation.

**WARNING**

- Any person who is involved with working on or breaking into a refrigerant circuit should hold a currently valid certificate from an industry-accredited assessment authority which authorises their competence to handle refrigerants safely in accordance with an industry recognised assessment specification.
- Servicing must only be performed as recommended by the equipment manufacturer. Maintenance and repair requiring the assistance of other skilled personnel must be carried out under the supervision of qualified personnel in the use of flammable refrigerants.
- Appliance must be stored in a well-ventilated area where the room size corresponds to the room area as specified for operation.
- Appliance must be stored in a room without continuously operating open flames (for example an operating gas appliance) and ignition sources (for example an operating electric heater).
- Appliance must be installed, operated and stored in a room with a floor area larger than X m<sup>2</sup>, installation of pipework must be kept to a minimum of X m<sup>2</sup> (Please see the following form). The appliance must not be installed in an unventilated space if that space is smaller than X m<sup>2</sup> (Please see the following form). Spaces with refrigerant pipes must comply with national gas regulations.





Model (Btu/h)	Amount of refrigerant to be charged (kg)	Maximum installation height (m)	Minimum room area (m <sup>2</sup> )
≤30000	≤2.048	1.8 m	4
30000-48000	2.048-3.0	1.8 m	8
>48000	>3.0	1.8 m	9

Table 2.

**Note about Fluorinated Gases**

1. This air-conditioning unit contains fluorinated gases. For specific information on the type of gas and the amount, please refer to the relevant label on the unit itself.
2. Installation, service, maintenance and repair of this unit must be performed by a qualified personnel.
3. Product de-installation and recycling must be performed by a qualified personnel.
4. If the system has a leak-detection system installed, it must be checked for leaks at least every 12 months.
5. When the unit is checked for leaks, proper record-keeping of all checks is strongly recommended.

**Explanation of symbols displayed on the indoor unit or outdoor unit  
(applicable to the unit with R32 refrigerant only):**

	<b>WARNING</b>	This symbol shows that this appliance uses a flammable refrigerant. If the refrigerant is leaked and exposed to an external ignition source, there is a risk of fire.
	<b>CAUTION</b>	This symbol shows that the operation manual should be read carefully.
	<b>CAUTION</b>	This symbol shows that service personnel should handle this equipment with reference to the installation manual.
	<b>CAUTION</b>	This symbol shows that information is available such as the operating manual or installation manual.
	<b>CAUTION</b>	This symbol shows that information is available such as the operating manual or installation manual.

### 3 Installation Overview

#### INSTALLATION ORDER

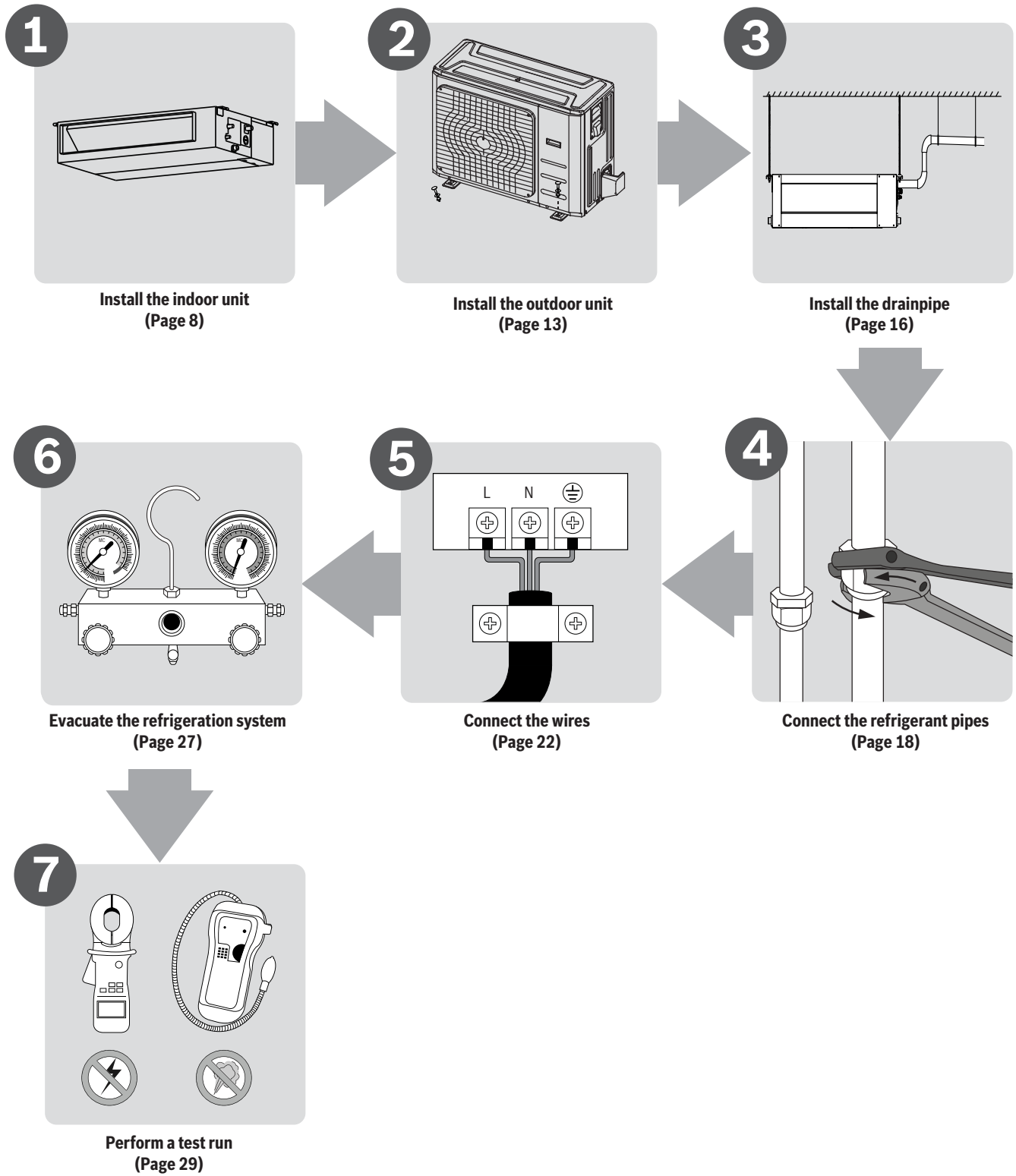

## 4 Indoor Unit Installation

### 4.1 Indoor Unit Parts

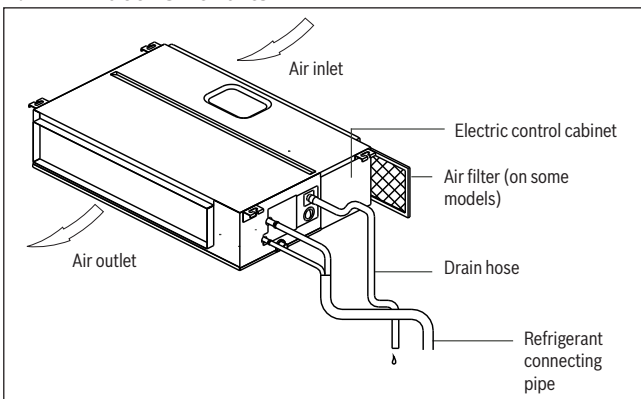

Fig. 1.

#### Safety Precautions

##### **WARNING**

- Securely install the indoor unit on a structure that can sustain its weight. If the structure is too weak, the unit may fall causing personal injury, unit and property damage or death.
- **DO NOT** install the indoor unit in the bathroom or laundry room as excessive moisture can short the unit and corrode the wiring.

##### **CAUTION**

- Install the indoor and outdoor units, cables and wires at least 1 m from televisions or radios to prevent static or image distortion. Depending on the appliances, a 1 m distance may not be sufficient.
- If the indoor unit is installed on a metal part of the building, it must be electrically grounded.

## 4.2 Indoor Unit Installation Instructions

### Step 1: Select installation location

The indoor unit should be installed in a location that meets the following requirements:

- ▶ Enough room exists for installation and maintenance.
- ▶ Enough room exists for the connecting pipe and drainpipe.
- ▶ The ceiling is horizontal and its structure can sustain the weight of the indoor unit.
- ▶ The air inlet and outlet are not impeded.
- ▶ The airflow can fill the entire room.
- ▶ There is no direct radiation from heaters.
- ▶ Models with a cooling capacity of 9000 Btu to 18000 Btu only apply to one room.

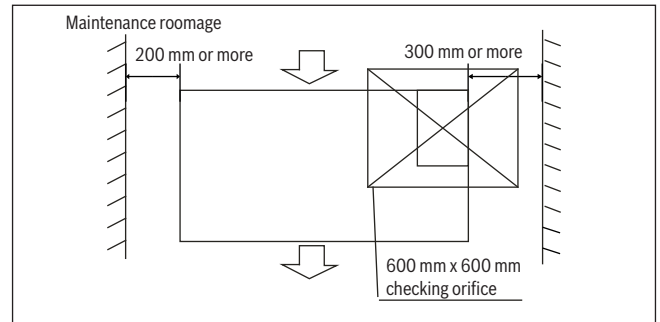

Fig. 2.

##### **CAUTION**

**DO NOT** install the unit in the following locations:

- ⊘ In areas with oil drilling or fracking
- ⊘ In coastal areas with high salt content in the air
- ⊘ In areas with caustic gases in the air, such as near hot springs
- ⊘ In areas with power fluctuations, such as factories
- ⊘ In enclosed spaces, such as cabinets In kitchens that use natural gas
- ⊘ In areas with strong electromagnetic waves in areas that store flammable materials or gas
- ⊘ In rooms with high humidity, such as bathrooms or laundry rooms

**Step 2: Hang indoor unit.**

1. Please refer to the following diagrams to locate the four positioning screw bolt holes on the ceiling. Ensure to mark the places where you will drill ceiling hook holes.

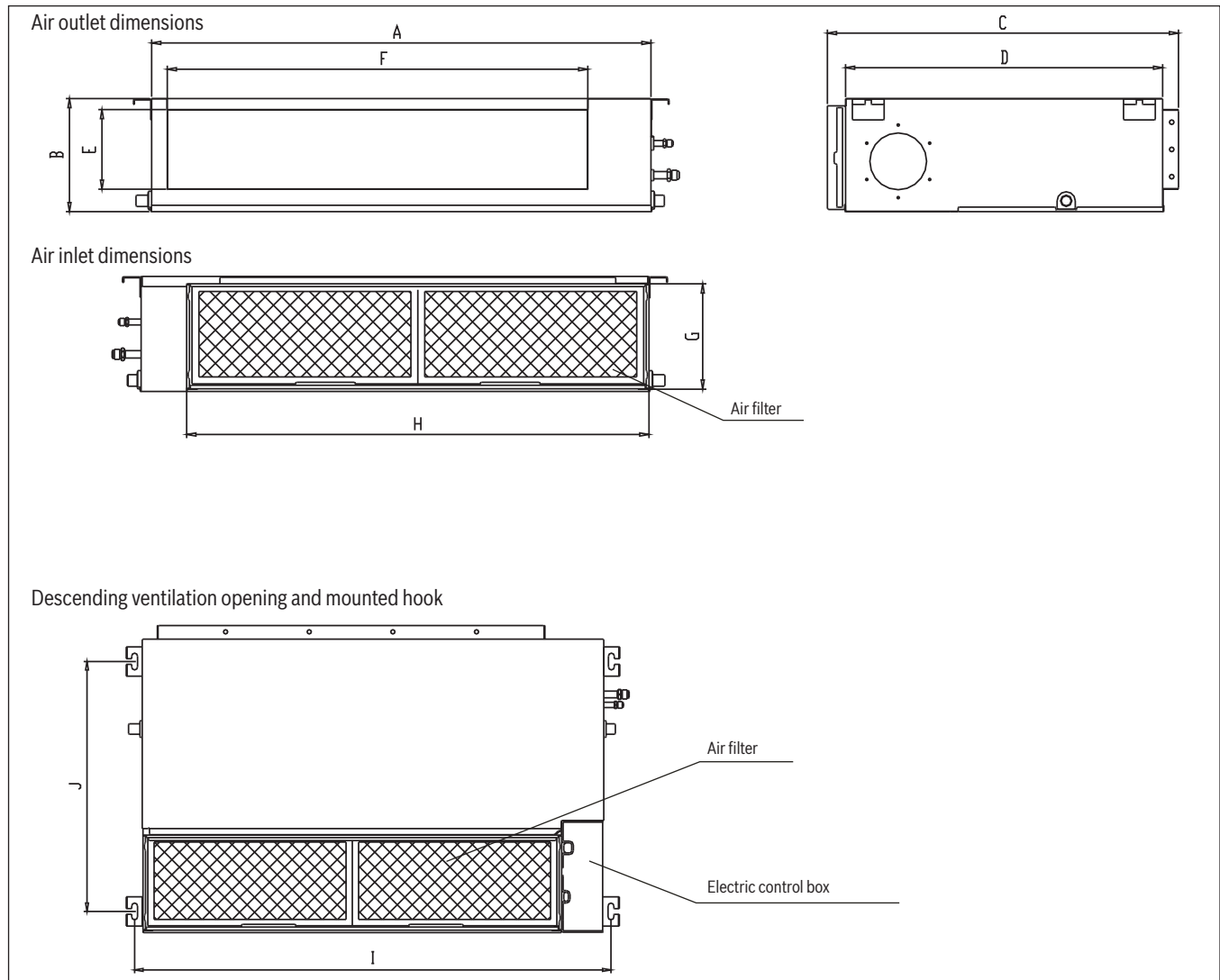

Fig. 3.

MODEL (Btu/h)	Outline dimension				Air outlet opening size		Air return opening size		Size of mounted lug	
	A	B	C	D	E	F	G	H	I	J
18K	880	210	674	600	136	706	190	782	920	508
24K	1100	249	774	700	175	926	228	1001	1140	598
30K~36K	1360	249	774	700	175	1186	228	1261	1400	598
36K~60K	1200	300	874	800	227	1044	280	1101	1240	697

Table 3. (unit: mm)

**Wood**

Place the wood mounting across the roof beam, then install the hanging screw bolts. (See Fig. 4)

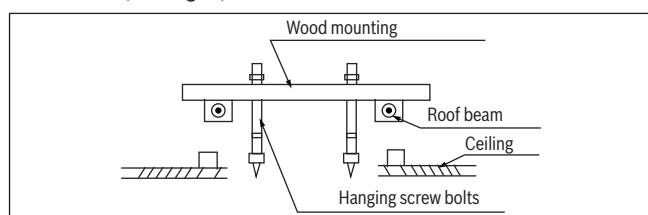

Fig. 4.

**New concrete bricks**

Inlay or embed the screw bolts. (See Fig. 5)

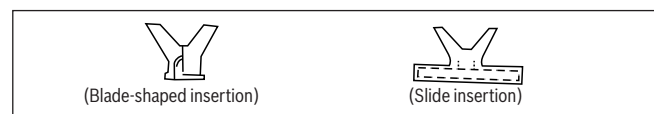

Fig. 5.



**Original concrete bricks**

Use an embedding screw bolt, crock, and stick harness. (See Fig. 6)

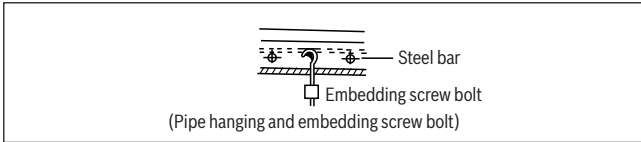

Fig. 6.

**Steel roof beam structure**

Install and use the supporting steel angle. (See Fig. 7)

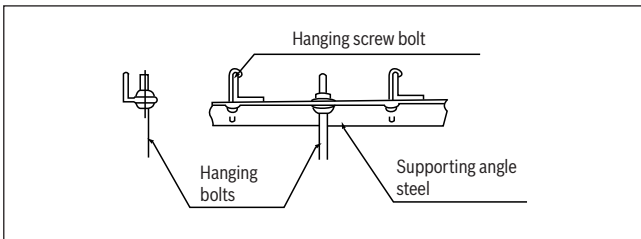

Fig. 7.

**CAUTION**

The unit body must be completely aligned with the hole. Ensure that the unit and the hole are the same size before moving on.

1. Install and fit pipes and wires after you have finished installing the main body. When choosing where to start, determine the direction of the pipes to be drawn out. Especially in cases where there is a ceiling involved, align the refrigerant pipes, drain pipes, and indoor and outdoor lines with their connection points before mounting the unit.
2. Install hanging screw bolts.
  - Cut off the roof beam.
  - Strengthen the point at which the cut was made. Consolidate the roof beam.
3. After you select an installation location, align the refrigerant pipes, drain pipes, as well as indoor and outdoor wires with their connection points before mounting the unit.
4. Drill 4 holes 10 cm deep at the ceiling hook positions in the internal ceiling. Ensure to hold the drill at a 90° angle to the ceiling.
5. Secure the bolt using the washers and nuts provided.
6. Install the four suspension bolts.
7. Mount the indoor unit with at least two people to lift and secure it. Insert suspension bolts into the unit's hanging holes. Fasten them using the washers and nuts provided. (See Fig. 8).

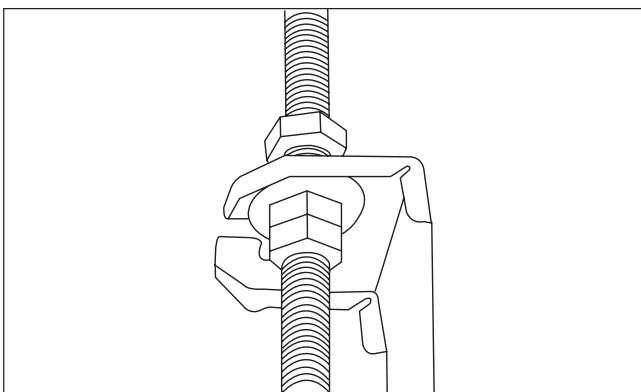

Fig. 8.

8. Mount the indoor unit onto the hanging screw bolts with a block. Position the indoor unit flat using a level indicator to prevent leaks. (See Fig. 9).

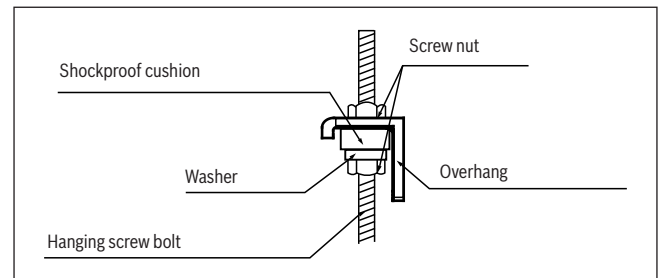

Fig. 9.

**NOTE:**

Confirm the minimum drain tilt is 1/100 or more.

**Step 3: Duct and accessories installation**

1. Install the filter (optional) according to the size of the air inlet.
2. Install the canvas tie-in between the body and duct.
3. The air inlet and air outlet duct should be far enough apart to avoid air passage short-circuit.
4. Connect the duct according to the following diagram:

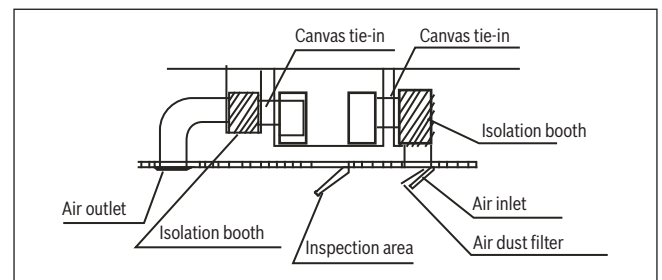

Fig. 10.

5. Refer to the following static pressure guidelines when installing the indoor unit.

MODEL (Btu/h)	Static Pressure (Pa)
18K	0~100
24K	0~160
30K~36K	0~160
42K~60K	0~160

Table 4.

Change the fan motor static pressure according to external duct static pressure.

**NOTE:**

1. Do not place the connecting duct weight on the indoor unit.
2. When connecting the duct, use a nonflammable canvas tie-in to prevent vibrating.
3. Insulation foam must be wrapped outside the duct to avoid condensate. An internal duct underlayer can be added to reduce noise, if the end-user requires.

**Step 4: Adjust the air inlet direction (From rear side to underside)**

1. Take off the ventilation panel and flange.

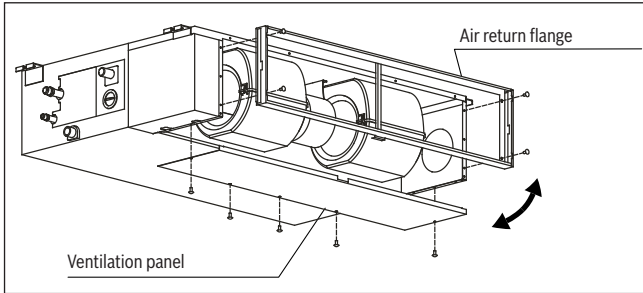

Fig. 11.

2. Change the mounting positions of the ventilation panel and air return flange.

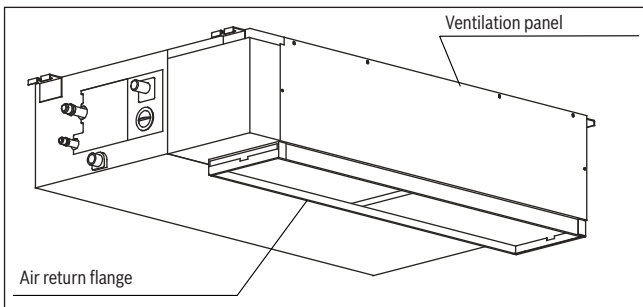

Fig. 12.

3. When installing the filter mesh, fit it into the flange as illustrated in the following figure.

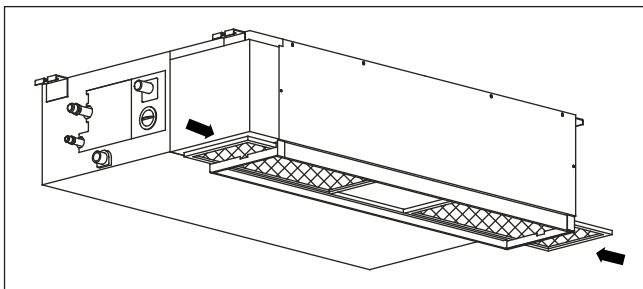

Fig. 13.

**NOTE:**

All the figures in this manual are for demonstration purposes only. The air conditioner you have purchased may be slightly different in design, though similar in shape.

**Step 5: Fresh air duct installation**

Dimension :

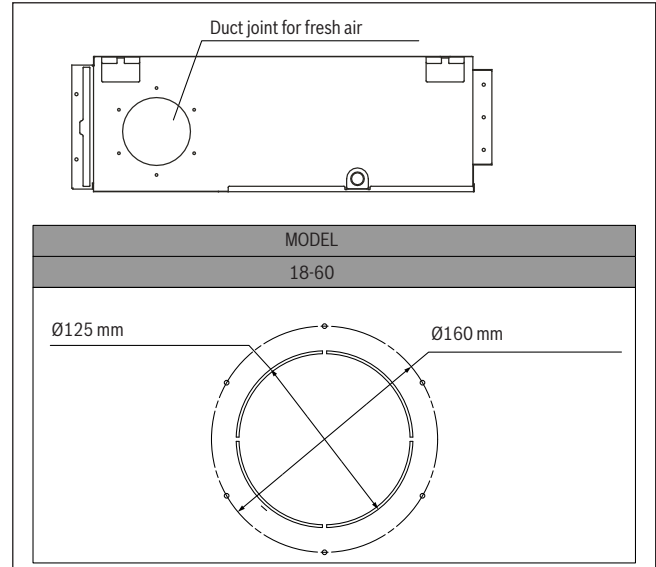

Fig. 14.

**Step 6: Motor and drain pump maintenance**

(The rear ventilated panel is used as an example)

**Motor maintenance:**

1. Take off the ventilated panel.
2. Take off the blower housing.
3. Take off the motor.

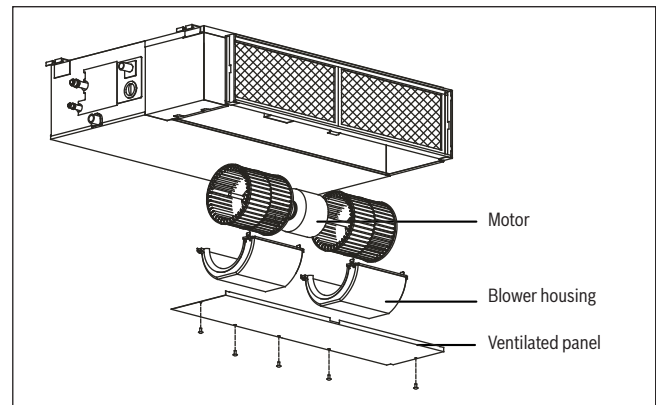

Fig. 15.

**Pump maintenance:**

1. Remove four screws from the drain pump.
2. Unplug the pump power supply and water level switch cable.
3. Detach the pump.

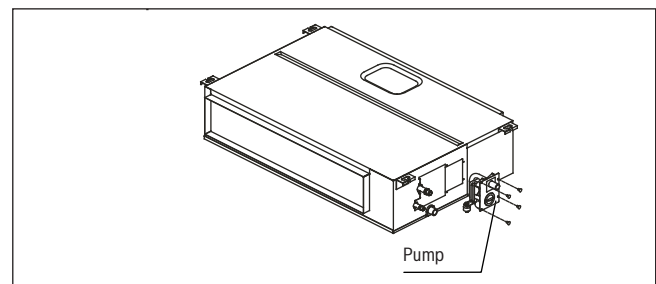

Fig. 16.

## 5 Outdoor Unit Installation

### 5.1 Outdoor Unit Installation Instructions

#### Step 1: Select installation location.

The outdoor unit should be installed in a location that meets the following requirements:

- ▶ Place the outdoor unit as close to the indoor unit as possible.
- ▶ Ensure that there is enough room for installation and maintenance.
- ▶ The air inlet and outlet must not be obstructed or exposed to strong wind.
- ▶ Ensure the location of the unit will not be subject to snowdrifts, accumulation of leaves or other seasonal debris. If possible, provide an awning for the unit. Ensure the awning does not obstruct airflow.
- ▶ The installation area must be dry and well ventilated.
- ▶ There must be enough room to install the connecting pipes and cables and to access them for maintenance.

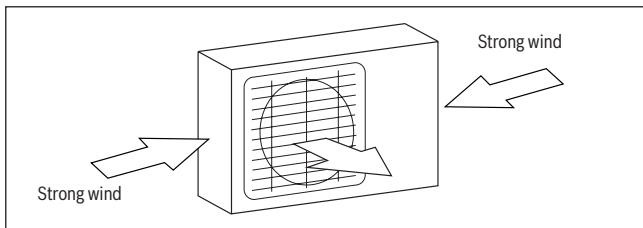

Fig. 17.

- ▶ The area must be free of combustible gases and chemicals.
- ▶ The pipe length between the outdoor and indoor unit may not exceed the maximum allowable pipe length.
- ▶ If possible, **DO NOT** install the unit where it is exposed to direct sunlight.
- ▶ If possible, ensure the unit is located far away from your neighbours property so that the noise from the unit will not disturb them.
- ▶ If the location is exposed to strong winds (for example: near a seaside), the unit must be placed against the wall to shelter it from the wind. If necessary, use an awning. (See Fig. 17 & 18)
- ▶ Install the indoor and outdoor units, cables and wires at least 1 metre from televisions or radios to prevent static or image distortion. Depending on the radio waves, a 1 metre distance may not be enough to eliminate all interference.

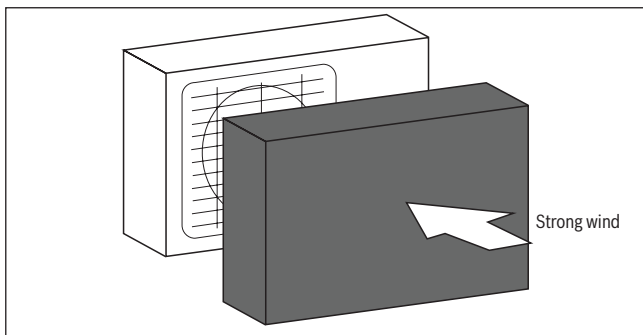

Fig. 18.

#### Step 2: Install outdoor unit.

Fix the outdoor unit with anchor bolts (M10)

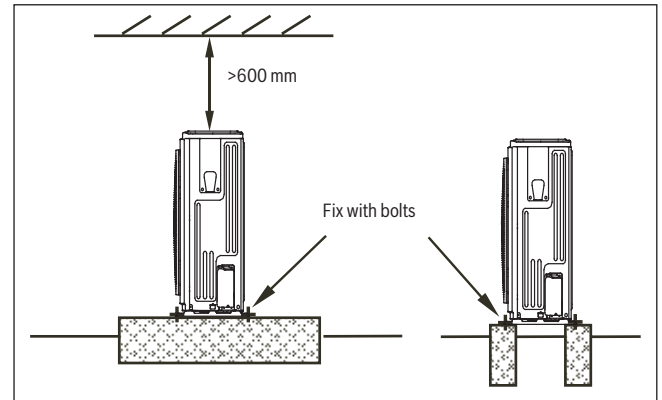

Fig. 19.

#### **CAUTION**

- Ensure to remove any obstacles that may block air circulation.
- Ensure you refer to the length specifications to ensure there is enough room for installation and maintenance.

#### Split Type Outdoor Unit

(Refer to Fig 20, 21, 22, 26 and Table 5)

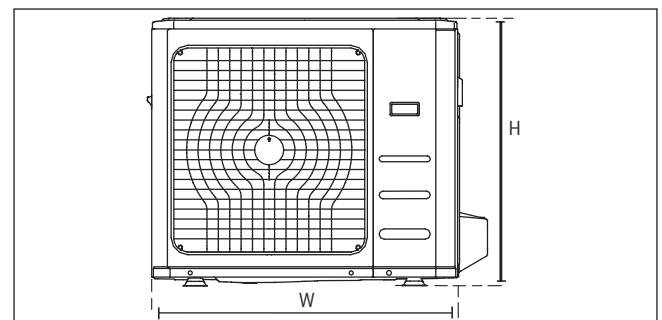

Fig. 20.

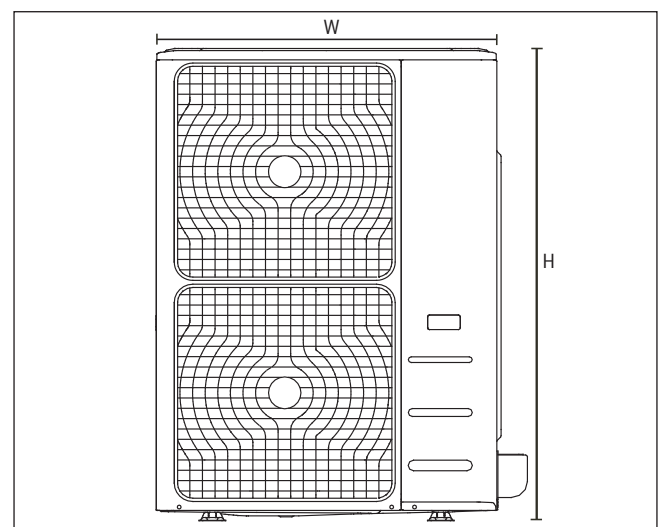

Fig. 21.

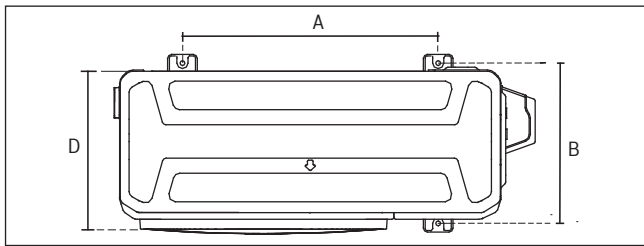

Fig. 22.

Outdoor Unit Dimensions W x H x D	Mounting Dimensions	
	Distance A	Distance B
760x590x285	530	290
810x558x310	549	325
845x700x320	560	335
900x860x315	590	333
945x810x395	640	405
990x965x345	624	366
938x1369x392	634	404
900x1170x350	590	378
800x554x333	514	340
845x702x363	540	350
946x810x420	673	403
946x810x410	673	403
952x1333x410	634	404
952x1333x415	634	404

Table 5. Length Specifications of Split Type Outdoor Unit (unit: mm)

Table 6.

**NOTE:**

The minimum distance between the outdoor unit and walls described in the installation guide does not apply to airtight rooms. Be sure to keep the unit unobstructed in at least two of the three directions (M, N, P) (See Fig. 23)

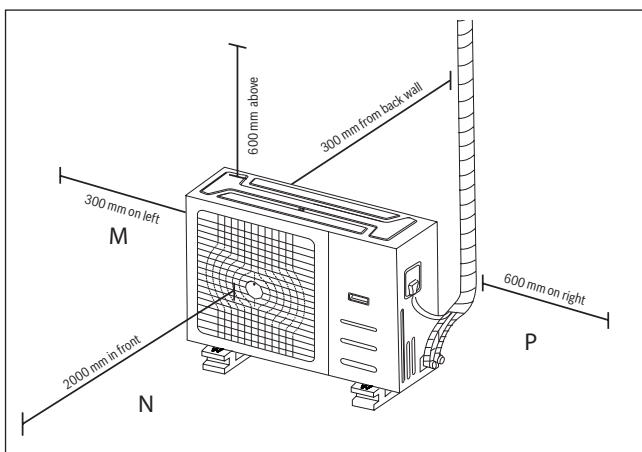

Fig. 23.

**Rows of series installation**

	L	A
L ≤ H	L ≤ 1/2H	250 mm or more
	1/2H < L ≤ H	300 mm or more
L > H	Cannot be installed	

Table 7. The relations between H, A and L are as follows

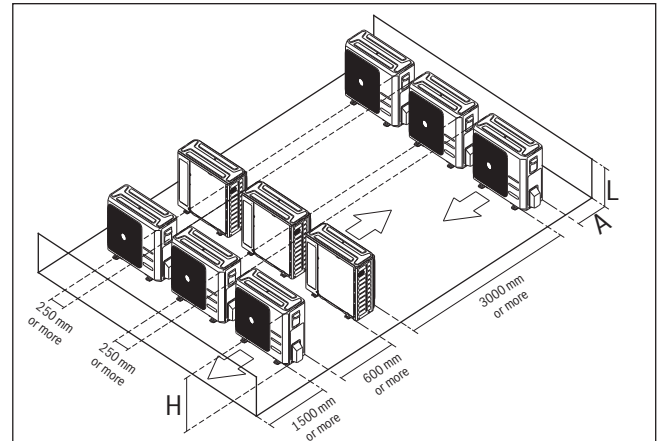

Fig. 24.

**5.2 Drain Joint Installation**

If the drain joint comes with a rubber seal (see Fig. 25 - A ), do the following:

1. Fit the rubber seal on the end of the drain joint that will connect to the outdoor unit.
2. Insert the drain joint into the hole in the base pan of the unit.
3. Rotate the drain joint 90° until it clicks in place facing the front of the unit.
4. Connect a drain hose extension (not included) to the drain joint to redirect water from the unit during heating mode.

If the drain joint does not come with a rubber seal (see Fig. 25 - B ), do the following:

1. Insert the drain joint into the hole in the base pan of the unit. The drain joint will click in place.
2. Connect a drain hose extension (not included) to the drain joint to redirect water from the unit during heating mode.

**NOTE:**

Ensure the water drains to a safe location where it will not cause water damage or a slipping hazard.

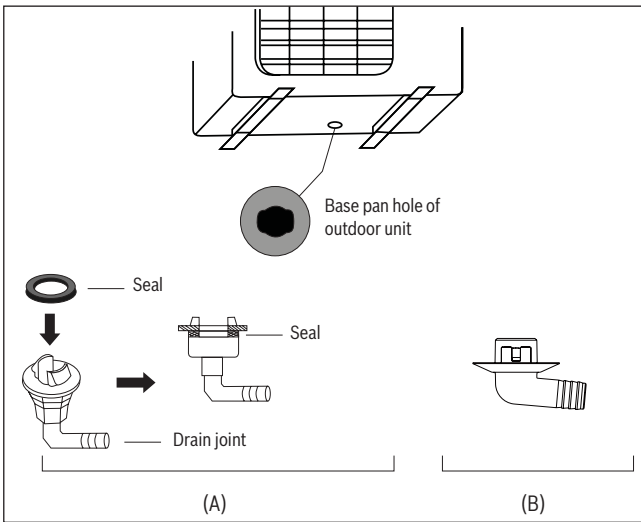

Fig. 25.

### 5.3 Notes On Drilling a Hole in the Wall

You must drill a hole in the wall for the refrigerant piping and the signal cable that will connect the indoor and outdoor units.

1. Determine the location of the wall hole based on the location of the outdoor unit.
2. Using a 65 mm core drill, drill a hole in the wall.

**NOTE:**

When drilling the wall hole, ensure to avoid wires, plumbing, and other sensitive components.

3. Place the protective wall cuff in the hole. This protects the edges of the hole and will help seal it when you finish the installation process.

## 6 Drainpipe Installation

The drainpipe is used to drain water from the unit. Improper installation may cause unit and property damage.

**CAUTION**

- Insulate all piping to prevent condensation, which could lead to water damage.
- If the drainpipe is bent or installed incorrectly, water may leak and cause a water-level switch malfunction.
- In HEAT mode, the outdoor unit will discharge water. Ensure that the drain hose is placed in an appropriate area to avoid water damage and slippage.
- **DO NOT** pull the drainpipe forcefully. This could disconnect it.

**NOTE ON PURCHASING PIPES**

This installation requires a polyethylene tube (outside diameter = 37 - 39 mm, inside diameter = 32 mm), which can be obtained at your local hardware store or dealer.

### Indoor Drainpipe Installation

Install the drainpipe as shown in Figure 30.

1. Cover the drainpipe with heat insulation to prevent condensation and leakage.
2. Attach the mouth of the drain hose to the unit's outlet pipe. Sheath the mouth of the hose and clip it firmly with a pipe clamp. (Fig. 29)

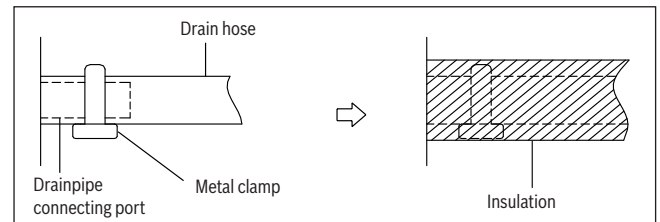

Fig. 26.

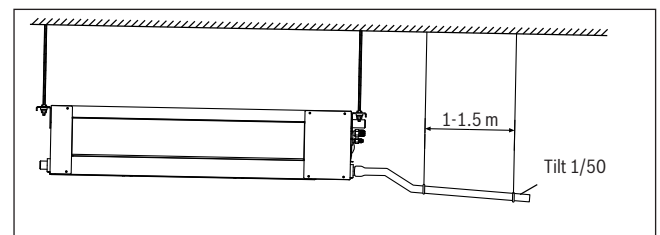

Fig. 27.

**NOTE ON DRAINPIPE INSTALLATION**

- When using an extended drainpipe, tighten the indoor connection with an additional protection tube. This prevents it from pulling loose.
- The drainpipe should slope downward at a gradient of at least 1/100 to prevent water from flowing back into the air conditioner. To prevent the pipe from sagging, space hanging wires every 1-1.5 m.
- If the outlet of the drainpipe is higher than the body's pump joint, use a lift pipe for the indoor unit's exhaust outlet. The lift pipe must be installed no higher than 550 mm from the ceiling board. The distance between the unit and the lift pipe must be less than 200 mm. Incorrect installation could cause water to flow back into the unit and flood.
- To prevent air bubbles, keep the drain hose level or slightly tilted up (<75 mm).

**Drainpipe installation for units with a pump**

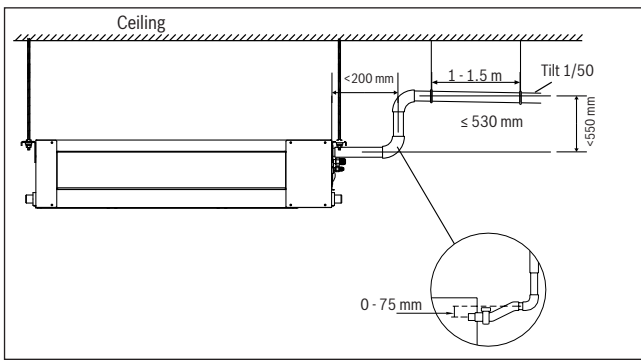

Fig. 28.

**NOTE:**

When connecting multiple drainpipes, install the pipes as illustrated in Fig. 29.

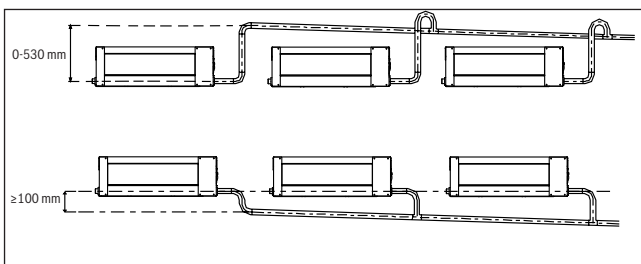

Fig. 29.

3. Using a 65 mm core drill, drill a hole in the wall. Make sure that the hole is drilled at a slight downward angle, so that the outdoor end of the hole is lower than the indoor end by about 12 mm. This will ensure proper water drainage (See Fig. 30). Place the protective wall cuff in the hole. This protects the edges of the hole and will help seal it once you finish installation.

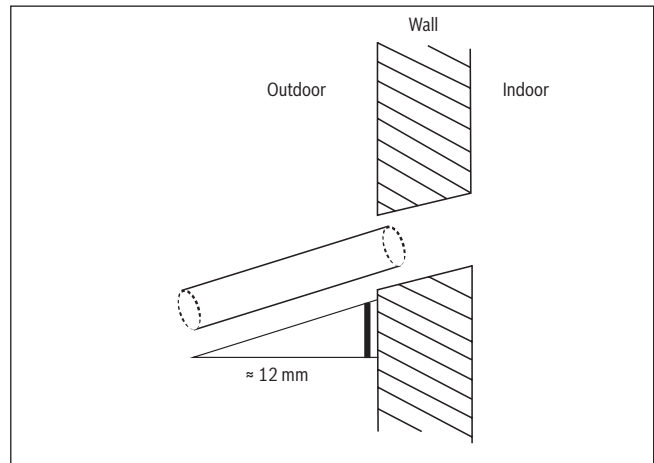

Fig. 30.

**NOTE:**

When drilling the hole, ensure to avoid wires, plumbing, and other sensitive components.

4. Pass the drain hose through the wall hole. Ensure the water drains to a safe location where it will not cause water damage or a slipping hazard.

**NOTE:**

The drainpipe outlet should be at least 5 cm above the ground. If it touches the ground, the unit may become blocked and malfunction. If you discharge the water directly into a sewer, ensure that the drain has a U or S pipe to catch odours that might otherwise come back into the house.

**Drainage test**

Check whether the drainpipe is unhindered. This test should be performed on newly built houses before the ceiling is paved.

**Units without a pump**

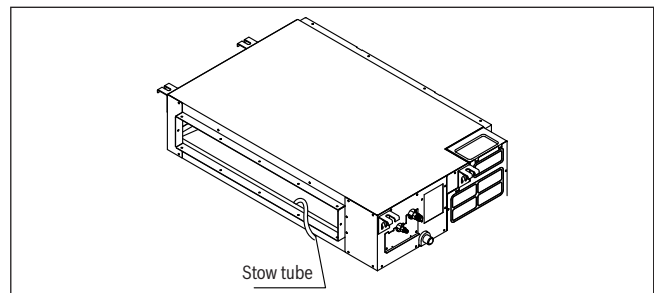

Fig. 31.

Fill the water pan with 2 liters of water. Check that the drainpipe is unhindered.

**Units with a pump**

1. Remove the test cover.  
Fill the water pan with 2 litres of water.

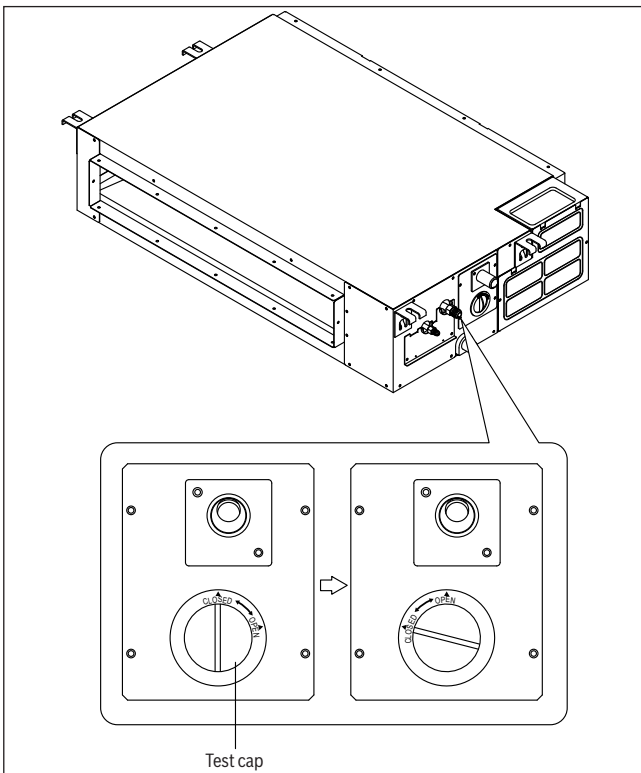

Fig. 32.

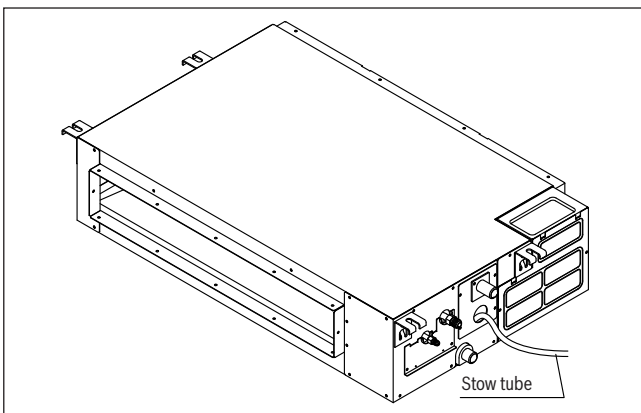

Fig. 33.

2. Turn on the unit in COOLING mode. You will hear the drain pump. Check whether the water is discharged properly (a 1-minute lag is possible, depending on the length of the drain pipe). Check whether water leaks from the joints.
3. Turn off the air conditioner and put the cap back on.

**7 Refrigerant Piping Connection**

**Safety Precautions**

**! WARNING**

- All field piping must be completed by a licensed technician and must comply with the local and national regulations.
- When the air conditioner is installed in a small room, measures must be taken to prevent the refrigerant concentration in the room from exceeding the safety limit in the event of refrigerant leakage. If the refrigerant leaks and its concentration exceeds its proper limit, hazards due to lack of oxygen may result.
- When installing the refrigeration system, ensure that air, dust, moisture or foreign substances do not enter the refrigerant circuit. Contamination in the system may cause poor operating capacity, high pressure in the refrigeration cycle, explosion or injury.
- Ventilate the area immediately if there is refrigerant leakage during the installation. Leaked refrigerant gas is both toxic and flammable. Ensure there is no refrigerant leakage after completing the installation work.

**7.1 Notes On Pipe Length and Elevation**

Ensure that the length of the refrigerant pipe, the number of bends, and the drop height between the indoor and outdoor units meets the requirements shown in Table 8:

Type of model	Capacity (Btu/h)	Length of piping	Maximum drop height
Split Inverter	<15K	25	10
	≥15K - <24K	30	20
	≥24K - <36K	50	25
	≥36K - ≤60K	65	30

Table 8. The Maximum Length and Drop Height Based on Models (Unit: m)

**Refrigerant Piping with Twin Indoor Units**

When installing multiple indoor units with a single outdoor unit, ensure that the length of the refrigerant pipe and the drop height between the indoor and outdoor units meet the requirements illustrated in the following diagram:

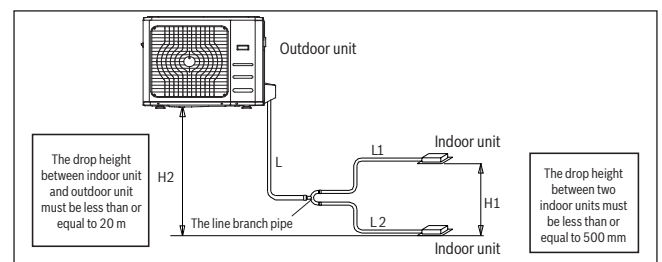

Fig. 34.

**! CAUTION**

- Oil traps  
If the outdoor unit is installed higher than the indoor unit:  
-It is recommended that vertical suction risers not be upsized. Proper oil return to the compressor should be maintained with suction gas velocity. If velocities drop below 7.62 m/s, oil return will be decreased. An oil trap should be installed every 6 m of vertical suction line riser. (See Fig. 35)

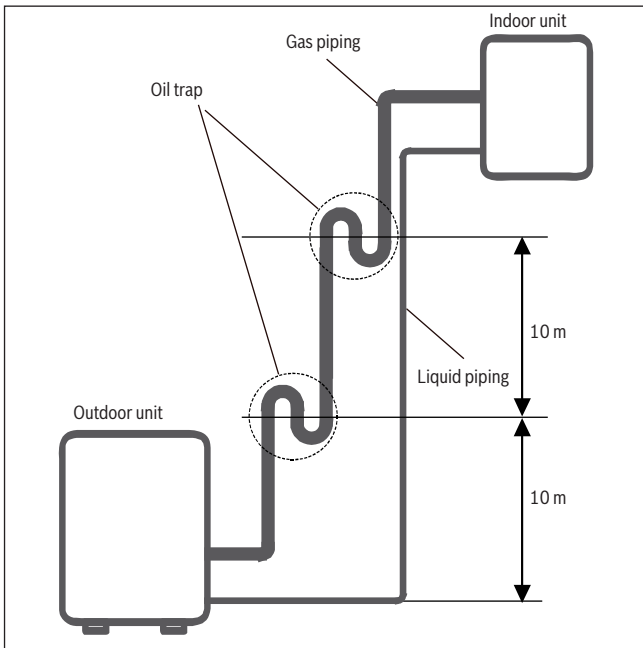

Fig. 35.

The indoor unit is installed higher than the outdoor unit

**CAUTION**

If the outdoor unit is installed higher than the indoor unit:  
 -It is recommended that vertical suction risers not be upsized. Proper oil return to the compressor should be maintained with suction gas velocity. If velocities drop below 7.62 m/s, oil return will be decreased. An oil trap should be installed every 6 m of vertical suction line riser. (See Fig. 36)

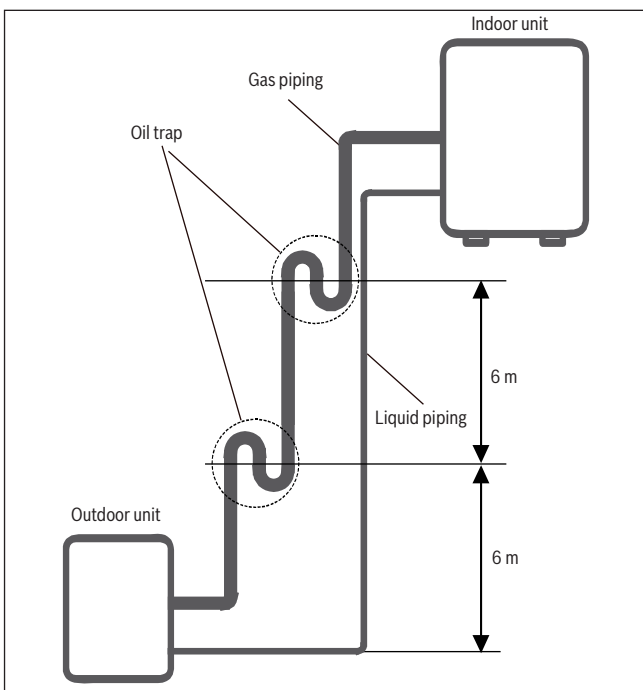

Fig. 36.

The outdoor unit is installed higher than the indoor unit

Permitted length				
Piping length	Total piping length	18K+18K	30	L+Max (L1, L2)
		24K+24K	50	
		30K+30K		
	(Farthest distance from the line pipe branch)	15		L1, L2
	(Farthest distance from the line pipe branch)	10		L1-L2
Drop height	Drop height between indoor and outdoor unit	20		H1
	Drop height between two indoor units	0.5		H2

Table 9.

**Size of joint pipes for indoor unit**

Capacity of indoor unit (A)	Size of main pipe (mm)	
	Gas side	Liquid side
18K	Ø12.7	Ø6.35
24K	Ø15.9	Ø9.5
30K	Ø15.9	Ø9.5

Table 10. Size of joint pipes

**Size of joint pipes for outdoor unit**

Base on the following tables, select the diameters of the outdoor unit connective pipes. If the main accessory pipe is larger than the main pipe, take the larger.

Model	Size of main pipe (mm)	
	Gas side	Liquid side
36K	Ø15.9	Ø9.5
42K - 48K	Ø15.9	Ø9.5
60K	Ø15.9	Ø9.5

Table 11. Size of joint pipes

**7.2 Refrigerant Piping Connection Instructions**

**CAUTION**

- **DO NOT** install the connecting pipe until both indoor and outdoor units have been installed.
- Insulate both the gas and liquid piping to prevent water leakage.



**Step 1: Cut pipes**

When preparing refrigerant pipes, take extra care to cut and flare them properly. This will ensure efficient operation and minimize the need for future maintenance.

1. Measure the distance between the indoor and outdoor units.
2. Using a pipe cutter, cut the pipe a little longer than the measured distance.

**CAUTION**

**DO NOT** deform pipe while cutting. Be extra careful not to damage, dent, or deform the pipe while cutting. This will drastically reduce the heating efficiency of the unit.

1. Make sure that the pipe is cut at a perfect 90° angle. Refer to Fig. 37 for examples of bad cuts

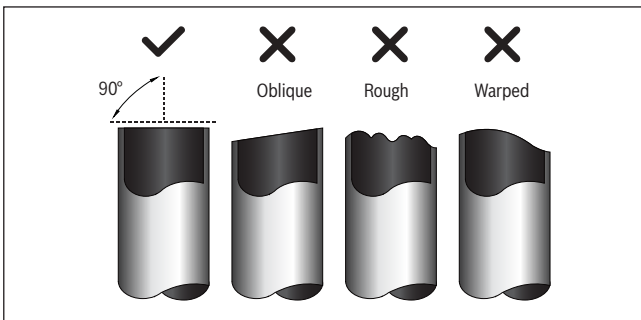

Fig. 37.

**Step 2: Remove burrs.**

Burrs can affect the air-tight seal of the refrigerant piping connection. They must be completely removed.

1. Hold the pipe at a downward angle to prevent burrs from falling into the pipe.
2. Using a reamer or deburring tool, remove all burrs from the cut section of the pipe.

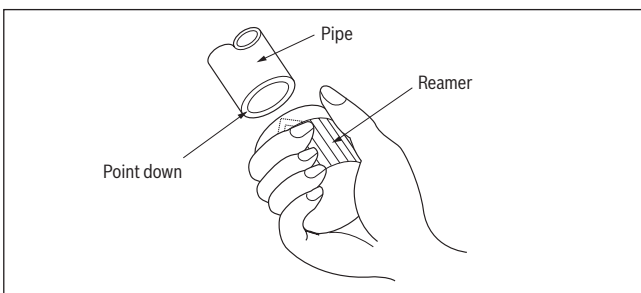

Fig. 38.

**Step 3: Flare pipe ends**

Proper flaring is essential to achieve an airtight seal.

1. After removing burrs from cut pipe, seal the ends with PVC tape to prevent foreign materials from entering the pipe.
2. Sheath the pipe with insulating material.
3. Place flare nuts on both ends of pipe. Ensure they are facing in the right direction, because you cannot put them on or change their direction after flaring. See Fig. 42.

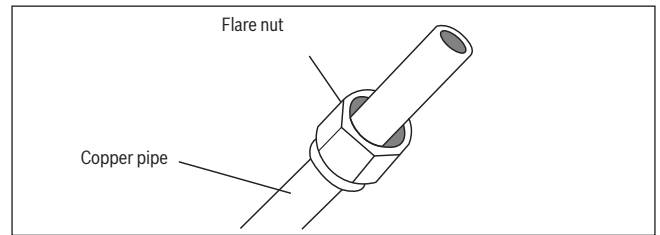

Fig. 39.

4. Remove PVC tape from ends of pipe when ready to perform flaring work.
5. Clamp flare form on the end of the pipe. The end of the pipe must extend beyond the flare form.

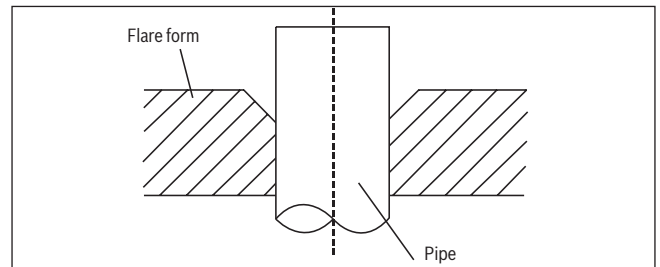

Fig. 40.

6. Place flaring tool onto the form.
7. Turn the handle of the flaring tool clockwise until the pipe is fully flared. Flare the pipe in accordance with the dimensions shown in table 12.

Pipe gauge	Tightening torque	Flare dimension (A) (Unit: mm)		Flare shape
		Min.	Max.	
Ø 6.4	18-20 N.m (183-204 kgf.cm)	8.4	8.7	
Ø 9.5	25-26 N.m (255-265 kgf.cm)	13.2	13.5	
Ø 12.7	35-36 N.m (357-367 kgf.cm)	16.2	16.5	
Ø 15.9	45-47 N.m (459-480 kgf.cm)	19.2	19.7	
Ø 19.1	65-67 N.m (663-683 kgf.cm)	23.2	23.7	
Ø 22	75-85 N.m (765-867 kgf.cm)	26.4	26.9	

Fig. 41.

Table 12. PIPING EXTENSION BEYOND FLARE FORM

8. Remove the flaring tool and flare form, then inspect the end of the pipe for cracks and even flaring.

**Step 4: Connect pipes**

Connect the copper pipes to the indoor unit first, then connect it to the outdoor unit. You should first connect the low-pressure pipe, then the high-pressure pipe.

1. When connecting the flare nuts, apply a thin coat of refrigeration oil to the flared ends of the pipes.
2. Align the center of the two pipes that you will connect.

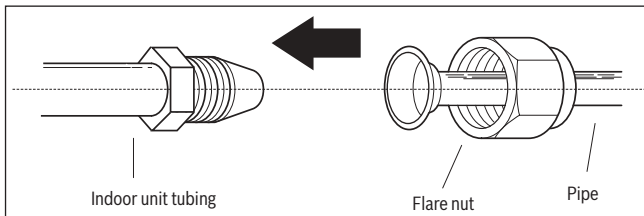

Fig. 42.

3. Tighten the flare nut as tightly as possible by hand.
4. Using a spanner, grip the nut on the unit tubing.
5. While firmly gripping the nut, use a torque wrench to tighten the flare nut according to the torque values in table 13.

**NOTE:**

Use both a spanner and a torque wrench when connecting or disconnecting pipes to/from the unit.

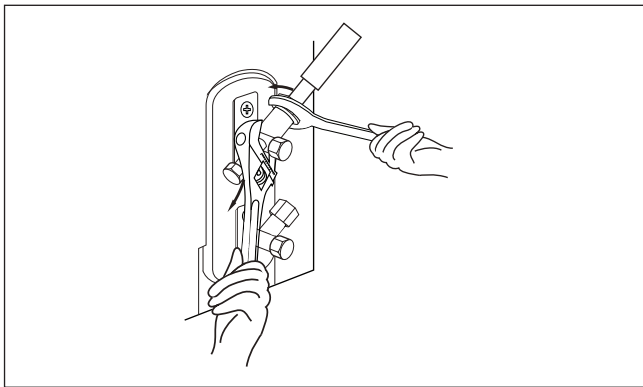

Fig. 43.

**CAUTION**

- Ensure to wrap insulation around the piping. Direct contact with the bare piping may result in burns or frostbite.
- Ensure the pipe is properly connected. Overtightening may damage the bell mouth and undertightening may lead to leakage.

**NOTE ON MINIMUM BEND RADIUS**

Carefully bend the tubing in the middle according to the diagram below. **DO NOT** bend the tubing more than 90° or more than 3 times.

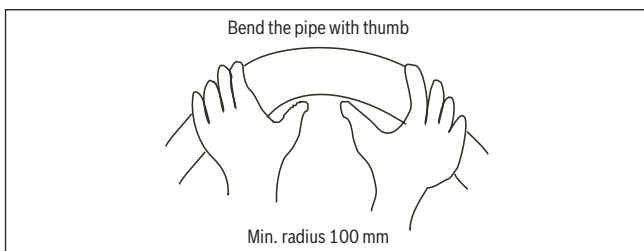

Fig. 44.

6. After connecting the copper pipes to the indoor unit, wrap the power cable, signal cable and the piping together with binding tape.

**NOTE:**

**DO NOT** intertwine signal cable with other wires. While bundling these items together, do not intertwine or cross the signal cable with any other wiring.

7. Thread this pipeline through the wall and connect it to the outdoor unit.
8. Insulate all the piping, including the valves of the outdoor unit.
9. Open the stop valves of the outdoor unit to start the flow of the refrigerant between the indoor and outdoor unit.

**CAUTION**

Ensure there is no refrigerant leak after completing the installation work. If there is a refrigerant leak, ventilate the area immediately and evacuate the system (refer to the Air Evacuation section of this manual).

## 8 Wiring

### Safety Precautions

- WARNING**
- Disconnect the power supply before working on the unit.
  - All wiring must be performed according to local and national regulations.
  - Wiring must be done by a qualified technician. Improper connections may cause electrical malfunction, injury, or fire.
  - An independent circuit and single outlet must be used for this unit. **DO NOT** plug another appliance or charger into the same outlet. If unit cannot handle the load or there is a defect in the wiring, it can lead to shock, fire, and unit and property damage.
  - Connect the power cable to the terminals and fasten it with a clamp. An insecure connection may cause fire.
  - Ensure that all wiring is done correctly and the control board cover is properly installed. Failure to do so can cause overheating at the connection points, fire, and electrical shock.
  - Ensure that the main power supply connection is made through a switch that disconnects all poles, with a contact gap of at least 3 mm.
  - **DO NOT** modify the length of the power cord or use an extension cord.

- CAUTION**
- Connect the outdoor wires before connecting the indoor wires.
  - Ensure you ground the unit. The grounding wire should be located away from gas pipes, water pipes, lightning rods, telephone wires or other grounding wires. Improper grounding may cause electrical shock.
  - **DO NOT** connect the unit to the power source until all wiring and piping is completed.
  - Ensure that you do not cross your electrical wiring with your signal wiring. This may cause distortion and interference.

To prevent distortion when the compressor starts (you can find the unit's power information on the rating sticker):

- The unit must be connected to the main outlet. Normally, the power supply must have a impedance of 32 ohms.
- No other equipment should be connected to the same power circuit.

### TAKE NOTE OF FUSE SPECIFICATIONS

The air conditioner's printed circuit board (PCB) is designed with a fuse that provides overcurrent protection. The specifications of the fuse are printed on the circuit board, such as:

**Indoor unit:** T5A/250VAC, T10A/250VAC (applicable for units with R32 refrigerant)

**Outdoor unit:** T20A/250VAC (for <24000 Btu/h unit), T30A/250VAC (for >24000 Btu/h unit)

**NOTE:**  
The fuse is made of ceramic.

## 8.1 Outdoor Unit Wiring

**WARNING**

Before performing any electrical or wiring work, isolate the main power to the system.

1. Prepare the cable for connection.
  - a. You must first choose the correct cable size before preparing it for connection. Ensure to use HO7RN-F cables.

Rated Current of Appliance (A)	Nominal Cross-Sectional Area (mm <sup>2</sup> )
≤6	0.75
6 - 10	1
10 - 16	1.5
16 - 25	2.5
25 - 32	4
32 - 45	6

Table 13. Minimum cross-sectional area of power and signal cable

- a. Using wire strippers, strip the rubber jacket from both ends of the signal cable to reveal approximately 150 mm of wire.
- c. Strip the insulation from the ends.
- d. Using a wire crimper, crimp u-lugs on the ends.

**NOTE:**  
When connecting the wires, strictly follow the wiring diagram found inside the electrical box cover.

2. Remove the electric cover of the outdoor unit. If there is no cover on the outdoor unit, take off the bolts from the maintenance board and remove the protection board. (See Fig. 45).

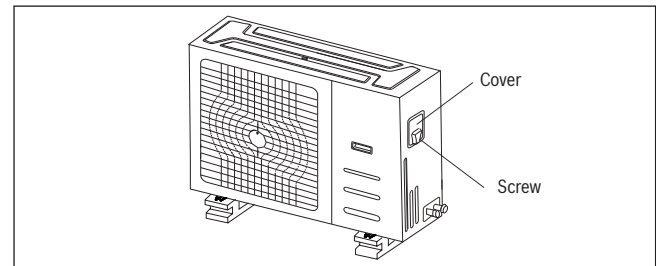

Fig. 45.

3. Connect the u-lugs to the terminals  
Match the wire colours/labels with the labels on the terminal block.  
Firmly screw the u-lug of each wire to its corresponding terminal.
4. Clamp down the cable with the cable clamp.
5. Insulate unused wires with electrical tape. Keep them away from any electrical or metal parts.
6. Re-install the cover of the electric control box.

### 8.2 Indoor Unit Wiring

1. Prepare the cable for connection.
  - a. Using wire strippers, strip the rubber jacket from both ends of the signal cable to reveal about 150 mm of the wire.
  - b. Strip the insulation from the ends of the wires.
  - c. Using a wire crimper, crimp the u-lugs to the ends of the wires.
2. Remove the cover of the electric control box on your indoor unit.
3. Connect the u-lugs to the terminals.  
Match the wire colours/labels with the labels on the terminal block.  
Firmly screw the u-lug of each wire to its corresponding terminal.  
Refer to the serial number and wiring diagram located on the cover of the electric control box.

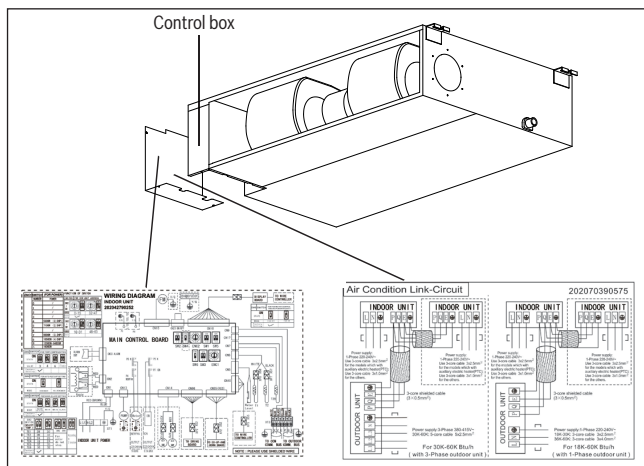

Fig. 46.

Magnetic ring (if supplied and packed with the accessories)

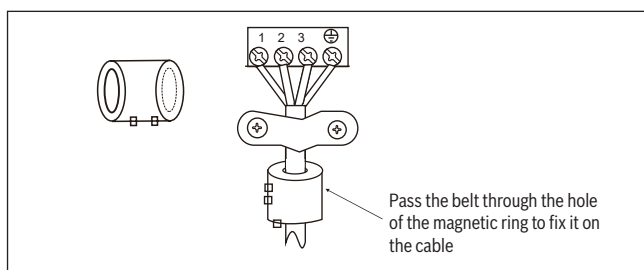

Fig. 47.

### CAUTION

- While connecting the wires, please strictly follow the wiring diagram.
- The refrigerant circuit can become very hot. Keep the interconnection cable away from the copper tube.

4. Clamp down the cable with the cable clamp. The cable must not be loose or pull on the u-lugs.
5. Reinstall the electric box cover .

### Using the wire controller to set external static pressure (some models)

- You can use the unit's automatic airflow adjustment function to set external static pressure.
- Automatic airflow adjustment is the volume of blow-off air that has been automatically adjusted to the quantity rated.

1. Make sure the test run is done with a dry coil. If the coil is not dry, run the unit for 2 hours in FAN ONLY mode to dry the coil.
2. Check that both power supply wiring and duct installation have been completed. Check that any closing dampers are open. Check that the air filter is properly attached to the air suction side passage of the unit.
3. If there is more than one air inlet and outlet, adjust the dampers so that the airflow rate of each air inlet and outlet conforms with the designed airflow rate. Ensure the unit is in FAN ONLY mode. Press and set the airflow adjustment button on the remote control to change the airflow rate from H or L.
4. Set the parameters for automatic airflow adjustment. When the air conditioning unit is off, perform the following steps:

- Press "COPY".
- Press "+" or "-" to select the AF.

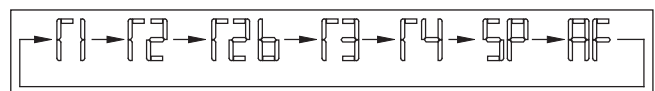

Fig. 48.

- Press "CONFIRM". The air conditioning unit will then start the fan for automatic airflow adjustment.

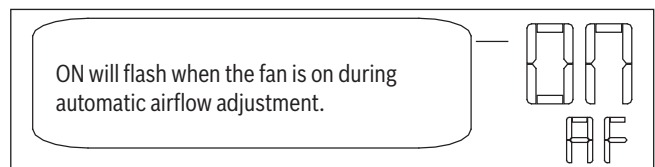

Fig. 49.

### CAUTION

- **DO NOT** adjust the dampers when automatic airflow adjustment is active.

After 3 to 6 minutes, the air conditioning unit stops operating once automatic airflow adjustment has finished.



**CAUTION**

- If there is no change in the ventilation paths after airflow adjustment, be sure to reset automatic airflow adjustment.
- If there is no change to ventilation paths after airflow adjustment, contact qualified personnel, especially if this occurs after testing the outdoor unit or if the unit has been moved to a different location.
- Do not use automatic airflow adjustment with remote control if you are using booster fans, outdoor air processing unit, or an HRV via duct.
- If the ventilation paths have been changed, reset airflow automatic adjustment as described from step 3 onwards.

**8.3 Power Specifications**

**NOTE:**

Electric auxiliary heating type circuit breaker/fuse need to add more than 10 A.

**Inverter Type A/C Power Specifications**

MODEL (Btu/h)		≤18K	19K~24K	25K~36K	≤36K	37K~60K
POWER (indoor)	PHASE	1 phase	1 phase	1 phase	1 phase	1 phase
	VOLT	220-240 V	220-240 V	220-240 V	220-240 V	220-240 V
CIRCUIT BREAKER/FUSE(A)		15/10	15/10	15/10	15/10	15/10
POWER (outdoor)	PHASE	1 phase	1 phase	1 phase	3 phase	3 phase
	VOLT	208-240 V	208-240 V	208-240 V	380-415 V	380-415 V
CIRCUIT BREAKER/FUSE(A)		25/20	25/20	40/30	25/20	32/25

Table 14.

## 9 Air Evacuation

### Safety Precautions

#### CAUTION

- Use a vacuum pump with a gauge reading lower than -0.1 MPa and an air discharge capacity above 40 L/min.
- The outdoor unit does not need vacuuming. **DO NOT** open the outdoor unit's gas and liquid stop valves.
- Ensure that the compound meter reads -0.1 MPa or below after 2 hours. If after three hours the gauge reading is still above -0.1 MPa, check if there is a gas leak or water inside the pipe. If there is no leak, perform another evacuation after 1 or 2 hours.
- **DO NOT** use refrigerant gas to evacuate the system.

### 9.1 Evacuation Instructions

Before using manifold gauge and vacuum pump, read their operation manuals to familiarize yourself with how to use them properly.

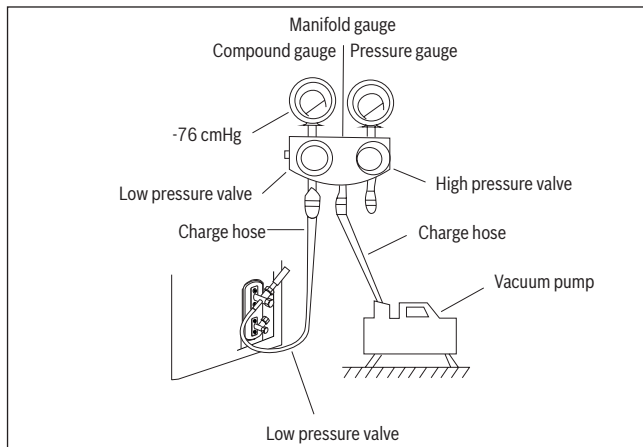

Fig. 50.

1. Connect the manifold gauge's charge hose to the service port on the outdoor unit's low pressure valve.
2. Connect the manifold gauge's charge hose from the service port to the vacuum pump.
3. Open the low pressure side of the manifold gauge. Keep the high pressure side closed.
4. Turn on the vacuum pump to evacuate the system.
5. Run the vacuum for at least 15 minutes or until the compound meter reads -76 cmHG (-1x10<sup>5</sup> Pa).
6. Close the manifold gauge's low pressure valve and turn off the vacuum pump.
7. Wait for 5 minutes, then check that there has been no change in system pressure.

#### NOTE:

If there is no change in system pressure, unscrew the cap from the packed valve (high pressure valve). If there is a change in system pressure, there may be a gas leak.

8. Insert hexagonal wrench into the packed valve (high pressure valve) and open the valve by turning the wrench in a 1/4 counterclockwise turn. Listen for gas to exit the system, then close the valve after 5 seconds.

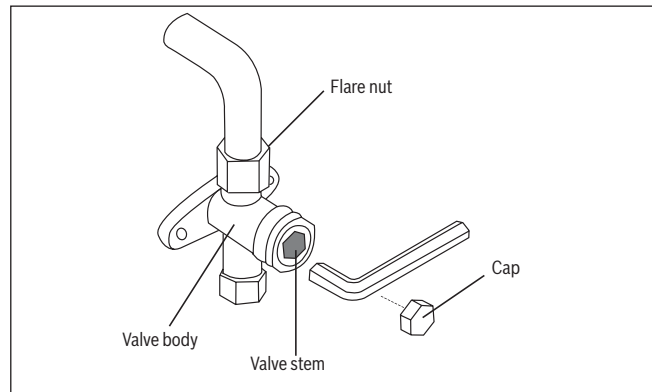

Fig. 51.

9. Watch the pressure gauge for one minute to ensure that there is no change in pressure. It should read slightly higher than the atmospheric pressure.
10. Remove the charge hose from the service port.
11. Using hexagonal wrench, fully open both the high pressure and low pressure valves.

#### OPEN VALVE STEMS GENTLY

When opening valve stems, turn the hexagonal wrench until it hits against the stopper. **DO NOT** try to force the valve to open further.

12. Tighten valve caps by hand, then tighten them using the proper tool.

### 9.2 Note On Adding Refrigerant

#### CAUTION

- Refrigerant charging must be performed after wiring, vacuuming, and the leak testing.
- **DO NOT** exceed the maximum allowable quantity of refrigerant or overcharge the system. Doing so can damage the unit or impact its functioning.
- Charging with unsuitable substances may cause explosions or accidents. Ensure that the appropriate refrigerant is used.
- Refrigerant containers must be opened slowly. Always use protective gear when charging the system.
- **DO NOT** mix refrigerants types.
- For the R32 refrigerant model, make sure the conditions within the area have been made safe by checking for flammable material when the refrigerant is added to the air conditioner.

Some systems require additional charging depending on pipe lengths. The standard pipe length varies according to local regulations:

**Liquid Side Diameter**

	Ø 6.35(1/4")	Ø 9.52(3/8")	Ø 12.7(1/2")
R410A (Orifice tube in the indoor unit):	(Total pipe length – standard pipe length) x 30 g (0.32 oZ)/m(ft)	(Total pipe length – standard pipe length) x 65g (0.69 oZ)/m(ft)	(Total pipe length – standard pipe length) x 115 g (1.23 oZ)/m(ft)
R410A (Orifice tube in the outdoor unit):	(Total pipe length – standard pipe length) x 15 g (0.16 oZ)/m(ft)	(Total pipe length – standard pipe length) x 30 g (0.32 oZ)/m(ft)	(Total pipe length – standard pipe length) x 65 g (0.69 oZ)/m(ft)
R32	(Total pipe length – standard pipe length) x 12 g(0.13 oZ)/m(ft)	(Total pipe length – standard pipe length)x 24 g (0.26 oZ)/m(ft)	(Total pipe length – standard pipe length) x 40 g (0.42 oZ)/m(ft)

Table 15.

## 10 Test Run

### Before Test Run

A test run must be performed after the entire system has been completely installed. Confirm the following points before performing the test:

- a. Indoor and outdoor units are correctly installed.
- b. Piping and wiring are properly connected.
- c. No obstacles near the inlet and outlet of the unit that might cause poor performance or product malfunction.
- d. Refrigeration system does not leak.
- e. Drainage system is unimpeded and draining to a safe location.
- f. Heating insulation is correctly installed.
- g. Grounding wires are correctly connected.
- h. Length of the piping and the added refrigerant stow capacity have been recorded.
- i. Power voltage is the correct voltage for the air conditioner.

**CAUTION**

Failure to perform the test run may result in unit damage, property damage or personal injury.

### Test Run Instructions

1. Open both the liquid and gas stop valves.
2. Turn on the main power switch and allow the unit to warm up.
3. Set the air conditioner to COOL mode.
4. For the indoor unit
  - a. Ensure the remote control and its buttons work correctly.
  - b. Ensure the louvres move correctly and can be changed using the remote control.
  - c. Double check to see if the room temperature is being registered correctly.
  - d. Ensure the indicators on the remote control and the display panel on the indoor unit work properly.
  - e. Ensure the manual buttons on the indoor unit work properly.
  - f. Check that the drainage system is unimpeded and draining smoothly.
  - g. Ensure there is no vibration or abnormal noise during operation.
5. For the outdoor unit
  - a. Check if the refrigeration system is leaking.
  - b. Make sure there is no vibration or abnormal noise during operation.
  - c. Ensure the wind, noise, and water generated by the unit do not disturb your neighbours or pose a safety hazard.
6. Drainage test

- a. Ensure the drainpipe flows smoothly. In the case of new buildings, this test should be performed before the ceiling is finished.
- b. Remove the test cover. Add 2,000 ml of water to the tank through the attached tube.
- c. Turn on the main power switch and run the air conditioner in COOL mode.
- d. Listen to the sound of the drain pump to see if it makes any unusual noises.
- e. Check that the water is discharged. It may take up to one minute before the unit begins to drain depending on the drainpipe.
- f. Ensure that there are no leaks in any of the piping.
- g. Stop the air conditioner. Isolate the main power switch and reinstall the test cover.

**NOTE:**

If the unit malfunctions or does not operate according to your expectations, please refer to the **Troubleshooting section** of the owner's manual before calling customer service.

## 11 European Disposal Guidelines

Users in European countries may be required to properly dispose of this unit. This appliance contains refrigerant and other potentially hazardous materials. When this appliance is disposed of the law requires special collection and treatment. **DO NOT** dispose of this product as household waste or unsorted municipal waste. When disposing of this appliance, you have the following options.

### NOTE:

Disposing of this appliance in the forest or other natural surroundings endangers your health and is bad for the environment. Hazardous substances may leak into the ground water and enter the food chain.

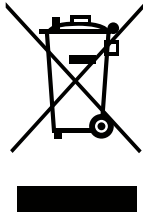

## 12 Information on Servicing

(Required for the units with R32 refrigerant only)

### 1. Checks to the area

Prior to beginning work on systems containing flammable refrigerants, safety checks are necessary to ensure that the risk of ignition is minimised. For repair to the refrigerating system, the following precautions must be complied with prior to conducting work on the system.

### 2. Work procedure

Works must be undertaken under a controlled procedure so as to minimise the risk of a flammable gas or vapour being present while the work is being performed.

### 3. General work area

All maintenance staff and others working in the local area must be instructed on the nature of work being carried out. Work in confined spaces must be avoided. The area around the work space must be sectioned off. Ensure that the conditions within the area have been made safe by checking for flammable material.

### 4. Checking for presence of refrigerant

The area must be checked with an appropriate refrigerant detector prior to and during work, to ensure the technician is aware of potentially flammable atmospheres. Ensure that the leak detection equipment being used is suitable for use with flammable refrigerants, i.e. no sparking, adequately sealed or intrinsically safe.

### 5. Presence of fire extinguisher

If any hot work is to be conducted on the refrigeration equipment or any associated parts, appropriate fire extinguishing equipment must be available to hand. Have a dry powder or CO<sub>2</sub> fire extinguisher adjacent to the charging area.

### 6. No ignition sources

No person carrying out work in relation to a refrigeration system which involves exposing any pipe work that contains or has contained flammable refrigerant must use any sources of ignition in such a manner that it may lead to the risk of fire or explosion. All possible ignition sources, including cigarette smoking, should be kept sufficiently far away from the site of installation, repairing, removing and disposal, during which flammable refrigerant can possibly be released to the surrounding space. Prior to work taking place, the area around the equipment is to be surveyed to make sure that there are no flammable hazards or ignition risks. "NO SMOKING" signs must be displayed.

### 7. Ventilated area

Ensure that the area is in the open or that it is adequately ventilated before opening the system or conducting any hot work. A degree of ventilation must continue during the period that the work is carried out. The ventilation should safely disperse any released refrigerant and preferably expel it externally into the atmosphere.

### 8. Checks to the refrigeration equipment

Where electrical components are being changed, they shall be fit for the purpose and meet the correct specification. The manufacturer's maintenance and service guidelines shall be followed at all times. If in doubt consult the manufacturer's technical department for assistance. The following checks shall be applied to installations using flammable refrigerants:

- The charge size is in accordance with the room size within which the refrigerant containing parts are installed.
- The ventilation machinery and outlets are operating adequately and are not obstructed.
- If an indirect refrigerating circuit is being used, the secondary circuits must be checked for the presence of refrigerant; marking on the equipment continues to be visible and legible.



- Marking and signs that are illegible must be corrected.
- Refrigeration pipe or components are installed in a position where they are unlikely to be exposed to any substance which may corrode refrigerant containing components, unless the components are constructed of materials which are inherently resistant to being corroded or are suitably protected against being so corroded.

### 9. Checks to electrical devices

Repair and maintenance to electrical components must include initial safety checks and component inspection procedures. If a fault exists that could compromise safety, then no electrical supply must be connected to the circuit until it is satisfactorily dealt with. If the fault cannot be corrected immediately but it is necessary to continue operation, an adequate temporary solution must be used. This must be reported to the owner of the equipment so all parties are advised.

#### Initial safety checks must include:

- Capacitors are discharged: this must be done in a safe manner to avoid possibility of sparking.
- No live electrical components and wiring are exposed while charging, recovering or purging the system.
- There is continuity of earth bonding.

### 10. Repairs to sealed components

10.1 During repairs to sealed components, all electrical supplies must be disconnected from the equipment being worked upon prior to any removal of sealed covers, etc. If it is absolutely necessary to have an electrical supply to equipment during servicing, then a permanently operating form of leak detection must be located at the most critical point to warn of a potentially hazardous situation.

10.2 Particular attention must be paid to the following to ensure that during work on electrical components, the casing is not altered in such a way that the level of protection is affected. This must include damage to cables, excessive number of connections, terminals not made to original specification, damage to seals, incorrect fitting of glands, etc.

- Ensure that the apparatus is mounted securely.
- Ensure that seals or sealing materials have not degraded such that they no longer serve the purpose of preventing the ingress of flammable atmospheres. Replacement parts must be in accordance with the manufacturer's specifications.

#### NOTE:

The use of silicon sealant may inhibit the effectiveness of some types of leak detection equipment. Intrinsically safe components do not have to be isolated prior to working on them.

### 11. Repair to intrinsically safe components

Do not apply any permanent inductive or capacitance loads to the circuit without ensuring that this will not exceed the permissible voltage and current permitted for the equipment in use. Intrinsically safe components are the only types that can be worked on while live in the presence of a flammable atmosphere. The test apparatus must be at the correct rating.

Replace components only with parts specified by the manufacturer. Other parts may result in the ignition of refrigerant in the atmosphere from a leak.

### 12. Cabling

Check that cabling will not be subject to wear, corrosion, excessive pressure, vibration, sharp edges or any other adverse environmental effects. The check must also take into account the effects of aging or continual vibration from sources such as compressors or fans.

### 13. Detection of flammable refrigerants

Under no circumstances may potential sources of ignition be used in searching for or detection of refrigerant leaks. A halide torch (or any other detector using a naked flame) must not be used.

### 14. Leak detection methods

The following leak detection methods are deemed acceptable for systems containing flammable refrigerants. Electronic leak detectors must be used to detect flammable refrigerants, but the sensitivity may not be adequate or may need re-calibration. (Detection equipment must be calibrated in a refrigerant-free area.) Ensure that the detector is not a potential source of ignition and is suitable for the refrigerant. Leak detection equipment must be set at a percentage of the LFL of the refrigerant and must be calibrated to the refrigerant employed. The appropriate percentage of gas (25% maximum) must be confirmed. Leak detection fluids are suitable for use with most refrigerants but the use of detergents containing chlorine must be avoided as the chlorine may react with the refrigerant and corrode the copper pipework.

If a leak is suspected, all naked flames must be removed or extinguished. If a leakage of refrigerant is found which requires brazing, all of the refrigerant must be recovered from the system or isolated (by means of shut off valves) in a part of the system remote from the leak. Oxygen free nitrogen (OFN) must then be purged through the system both before and during the brazing process.

### 15. Removal and evacuation

When breaking the refrigerant circuit to make repairs for any other purpose conventional procedures must be used, However, it is important that best practice be followed since flammability is a consideration. The following procedure must be adhered to:

- Remove refrigerant.
- Purge the circuit with inert gas.
- Evacuate.
- Purge again with inert gas.
- Open the circuit by cutting or brazing.

The refrigerant charge must be recovered into the correct recovery cylinders. The system must be flushed with OFN to render the unit safe. This process may need to be repeated several times. Compressed air or oxygen must not be used for this task.

Flushing must be achieved by breaking the vacuum in the system with OFN and continuing to fill until the working pressure is achieved, then venting to atmosphere, and finally pulling down to a vacuum. This process must be repeated until no refrigerant is within the system.

When the final OFN charge is used, the system must be vented down to atmospheric pressure to enable work to take place. This operation is absolutely vital if brazing operations on the pipework are to take place.

Ensure that the outlet for the vacuum pump is not closed to any ignition sources and there is ventilation available.

## 16. Charging procedures

In addition to conventional charging procedures, the following requirements must be met:

- Ensure that contamination of different refrigerants does not occur when using charging equipment. Hoses or lines must be as short as possible to minimize the amount of refrigerant contained in them.
- Cylinders must be kept upright.
- Ensure that the refrigeration system is earthed prior to charging the system with refrigerant.
- Label the system when charging is complete (if not already).
- Extreme care must be taken not to overfill the refrigeration system.
- Prior to recharging the system it must be pressure tested with OFN. The system must be leak tested on completion of charging but prior to commissioning. A follow up leak test must be carried out prior to leaving the site.

## 17. Decommissioning

Before carrying out this procedure, it is essential that the technician is completely familiar with the equipment and all its detail. It is recommended good practice that all refrigerants are recovered safely. Prior to the task being carried out, an oil and refrigerant sample must be taken.

If an analysis is required prior to re-use of reclaimed refrigerant, it is essential that electrical power is available before the task is commenced.

- a. Become familiar with the equipment and its operation.
- b. Isolate system electrically
- c. Before attempting the procedure ensure that:
  - mechanical handling equipment is available, if required, for handling refrigerant cylinders;
  - all personal protective equipment is available and being used correctly;
  - the recovery process is supervised at all times by a competent person;
  - recovery equipment and cylinders conform to the appropriate standards.
- d. Pump down refrigerant system, if possible.
- e. If a vacuum is not possible, make a manifold so that refrigerant can be removed from various parts of the system.
- f. Make sure that cylinder is situated on the scales before recovery takes place.
- g. Start the recovery machine and operate in accordance with manufacturer's instructions.
- h. Do not overfill cylinders. (No more than 80% volume liquid charge).
- i. Do not exceed the maximum working pressure of the cylinder, even temporarily.
- j. When the cylinders have been filled correctly and the process completed, make sure that the cylinders and the equipment are removed from site promptly and all isolation valves on the equipment are closed off.
- k. Recovered refrigerant must not be charged into another refrigeration system unless it has been cleaned and checked.

## 18. Labelling

Equipment must be labelled stating that it has been decommissioned and emptied of refrigerant. The label must be dated and signed. Ensure that there are labels on the equipment stating the equipment contains flammable refrigerant.

## 19. Recovery

- When removing refrigerant from a system, either for service or decommissioning, it is recommended good practice that all refrigerants are removed safely.
- When transferring refrigerant into cylinders, ensure that only appropriate refrigerant recovery cylinders are employed. Ensure that the correct number of cylinders for holding the total system charge are available. All cylinders to be used are designated for the recovered refrigerant and labelled for that refrigerant (i.e special cylinders for the recovery of refrigerant). Cylinders must be complete with pressure relief valve and associated shut-off valves in good working order.
- Empty recovery cylinders are evacuated and, if possible, cooled before recovery occurs.
- The recovery equipment must be in good working order with a set of instructions concerning the equipment that is at hand and must be suitable for the recovery of flammable refrigerants. In addition, a set of calibrated weighing scales must be available and in good working order.
- Hoses must be complete with leak-free disconnect couplings and in good condition. Before using the recovery machine, check that it is in satisfactory working order, has been properly maintained and that any associated electrical components are sealed to prevent ignition in the event of a refrigerant release. Consult manufacturer if in doubt.
- The recovered refrigerant must be returned to the refrigerant supplier in the correct recovery cylinder, and the relevant waste transfer note arranged. Do not mix refrigerants in recovery units and especially not in cylinders.
- If compressors or compressor oils are to be removed, ensure that they have been evacuated to an acceptable level to make certain that flammable refrigerant does not remain within the lubricant. The evacuation process must be carried out prior to returning the compressor to the suppliers. Only electric heating of the compressor body must be employed to accelerate this process. When oil is drained from a system, it must be carried out safely.

## 20. Transportation, marking and storage for units

1. Transport of equipment containing flammable refrigerants  
Compliance with the transport regulations
2. Marking of equipment using signs  
Compliance with local regulations
3. Disposal of equipment using flammable refrigerants  
Compliance with national regulations
4. Storage of equipment/appliances  
The storage of equipment should be in accordance with the manufacturer's instructions.
5. Storage of packed (unsold) equipment  
Storage package protection should be constructed such that mechanical damage to the equipment inside the package will not cause a leak of the refrigerant charge.  
The maximum number of pieces of equipment permitted to be stored together will be determined by local regulations.

The design and specifications are subject to change without prior notice for product improvement.  
Consult with the sales agency or manufacturer for details.

Bosch Thermotechnology Ltd  
Cotswold Way  
Warndon  
Worcester  
WR4 9SW

mailto: [Commercial.enquiry@uk.bosch.com](mailto:Commercial.enquiry@uk.bosch.com)  
Contact Number 03301233004  
Web address [www.bosch-industrial.co.uk](http://www.bosch-industrial.co.uk)