

# INSTALLATION AND MAINTENANCE INSTRUCTIONS

## EVACUATED TUBE COLLECTOR

# SOLAR-LUX 6/12

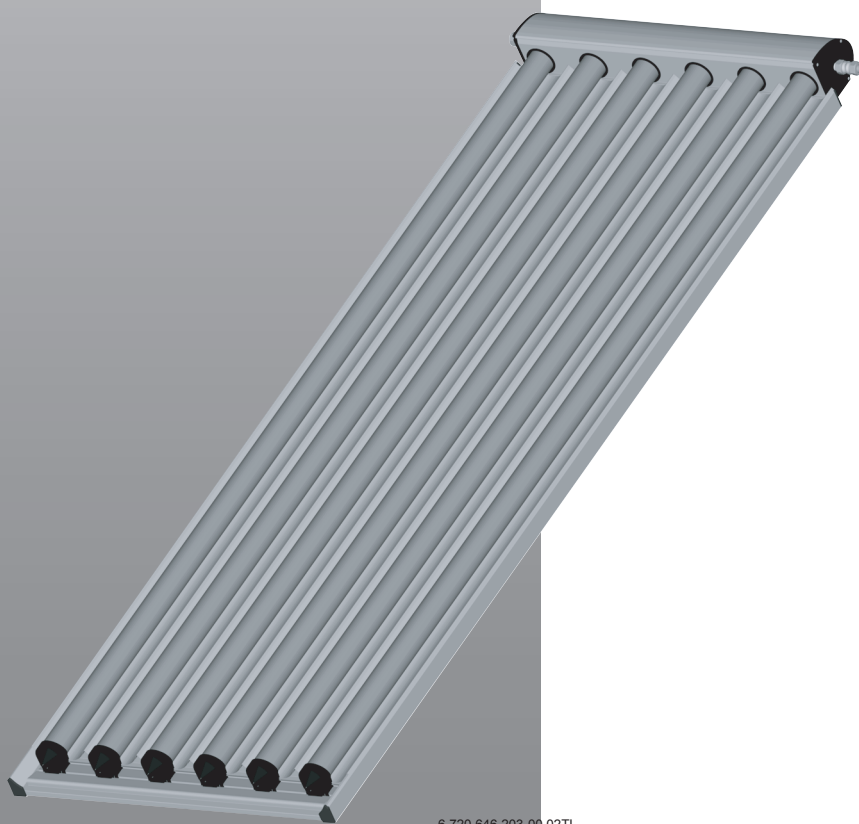

6 720 646 203-00.02TL

**FLAT ROOF INSTALLATION (30°, 45°)**

**WALL INSTALLATION (45°, 60°, 90°)**



# TABLE OF CONTENTS

<b>1</b>	<b>Key to symbols and safety instructions</b> . . . . .	<b>3</b>	<b>9</b>	<b>Installing the collectors</b> . . . . .	<b>19</b>
1.1	Explanation of symbols . . . . .	3	9.1	Installing the first collector . . . . .	19
1.2	General safety information . . . . .	3	9.2	Installing the second collector . . . . .	20
<b>2</b>	<b>Product information</b> . . . . .	<b>4</b>	9.3	Installing the collector sensor . . . . .	20
2.1	Components and instructions . . . . .	4	9.4	Installing the connection cover set (accessory) . . . . .	21
2.2	Correct use . . . . .	5	<b>10</b>	<b>Hydraulic connections</b> . . . . .	<b>22</b>
2.3	EU Declaration of Conformity . . . . .	5	<b>11</b>	<b>Final activities</b> . . . . .	<b>24</b>
2.4	Standard delivery . . . . .	6	11.1	Checking the installation . . . . .	24
2.4.1	Angle section frame (flat roof, walls) . . . . .	6	11.2	Pressure filling, purging, venting . . . . .	24
2.4.2	Mounting bracket (wall, 90°) . . . . .	6	11.3	Adjusting the pre-charge pressure of the expansion vessel . . . . .	24
2.4.3	Installation set . . . . .	6	11.4	Determining and setting the operating pressure . . . . .	24
2.4.4	Connection set (hydraulic connection) . . . . .	6	11.5	Adjusting the flow rate . . . . .	24
2.4.5	Collector . . . . .	7	11.6	Insulating piping . . . . .	24
2.5	Type plate . . . . .	7	<b>12</b>	<b>Replacing individual tubes</b> . . . . .	<b>25</b>
2.6	Specification . . . . .	7	<b>13</b>	<b>Environmental protection / disposal</b> . . . . .	<b>26</b>
<b>3</b>	<b>Regulations</b> . . . . .	<b>8</b>	<b>14</b>	<b>Maintenance/inspection</b> . . . . .	<b>27</b>
<b>4</b>	<b>Before installation</b> . . . . .	<b>9</b>			
4.1	Determining the angle of incidence of the collectors . . . . .	9			
4.2	Determining space requirements . . . . .	9			
4.2.1	Clearance between collector rows . . . . .	9			
4.2.2	Space requirement for the collector array . . . . .	9			
4.3	Planning the hydraulic connection . . . . .	10			
4.4	Observe general information . . . . .	11			
4.5	Concrete slabs for stabilising . . . . .	12			
4.6	Required tools and accessories . . . . .	12			
4.7	Lightning protection . . . . .	12			
4.8	Installation sequence . . . . .	12			
<b>5</b>	<b>Handling</b> . . . . .	<b>13</b>			
<b>6</b>	<b>Fitting the angle section frames</b> . . . . .	<b>14</b>			
6.1	Fitting the angle section frame on the flat roof . . . . .	14			
6.2	Fitting the angle section frame on the wall . . . . .	15			
<b>7</b>	<b>Fitting the mounting bracket</b> . . . . .	<b>16</b>			
<b>8</b>	<b>Rail installation</b> . . . . .	<b>17</b>			
8.1	Fitting the rails on the angle section frames . . . . .	17			
8.2	Fitting the rails on mounting brackets . . . . .	18			

# 1 KEY TO SYMBOLS AND SAFETY INSTRUCTIONS

## 1.1 EXPLANATION OF SYMBOLS

### WARNING SYMBOLS

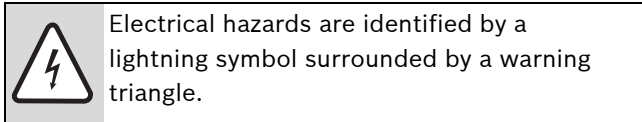
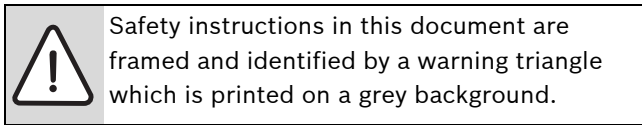

Signal words indicate the seriousness of the hazard in terms of the consequences of not following the safety instructions.

- **NOTICE** indicates possible damage to property or equipment, but where there is no risk of injury.
- **CAUTION** indicates possible injury.
- **WARNING** indicates possible severe injury.
- **DANGER** indicates possible risk to life.

### IMPORTANT INFORMATION

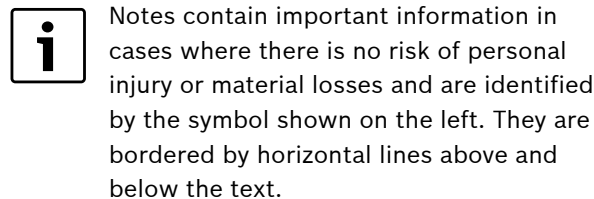

### ADDITIONAL SYMBOLS

Symbol	Meaning
▶	a step in an action sequence
→	a reference to a related part in the document or to other related documents
•	a list entry
–	a list entry (second level)

Tab. 1

## 1.2 GENERAL SAFETY INFORMATION

### DANGER OF FALLING WHEN WORKING ON THE ROOF

- ▶ If there are not any general anti-fall safety devices, wear personal protective clothing and safety equipment.
- ▶ Take appropriate action to prevent accidents during all work on roofs.
- ▶ Observe the health and safety regulations.

### DANGER OF BROKEN GLASS

If the glass tubes are destroyed, there is a risk of injury through falling glass.

- ▶ Avoid installing in public areas where falling glass could cause injury.

### RISK OF BECOMING BURNED BY THE COLLECTORS

If the collector and its installation material are left exposed to the sunlight for a long period, the parts will become hot.

- ▶ Care should be taken when working on the collector due to possible high temperatures.

### INSTALLATION

Installation and maintenance may only be carried out by a competent person. Do not alter the components.

- ▶ Please read these instructions carefully.
- ▶ Install the installation set only on roofs with sufficient load-bearing capacity. If necessary, consult a structural engineer and/or roofer.
- ▶ Do not walk on the collectors. Do not subject them to loads from objects at single points or over the entire surface area.
- ▶ After completing the installation, check that collectors and the installation set are securely positioned.

### FUNCTION CHECKS

The user is responsible for ongoing maintenance and safe upkeep of the system.

- ▶ Customer recommendation: Arrange a maintenance and inspection contract with a competent person.
- ▶ Only original spare parts must be used.

### INSTRUCTING THE CUSTOMER

- ▶ Notify customers about how the appliance works and provide training on operating the entire system.
- ▶ Inform customers that they must not carry out any modifications or repairs.
- ▶ Hand over the installation instructions to the customer and point out that these instructions must be kept and passed on to the next owner/user.

## 2 PRODUCT INFORMATION

### 2.1 COMPONENTS AND INSTRUCTIONS

The solar thermal system for DHW heating and/or central heating backup comprises various components (→ Fig. 1). These have instructions for installation, operation and maintenance. Some accessories have separate instructions. The following topics are described in the instructions for the components:

#### EVACUATED TUBE COLLECTORS (→ FIG. 1, [1])

- Installing the mounting brackets.
- Fastening the collectors.
- Hydraulic connection for the collectors.
- Maintenance for the collectors.

#### SOLAR PUMP STATION (→ FIG. 1, [2])

- Installing the solar pump station.
- Installing the piping.
- Commissioning the entire system.
- Maintenance for the solar pump station.
- Maintenance for the entire system.

#### CYLINDER (→ FIG. 1, [3])

- Positioning and installing the cylinder.
- Commissioning the cylinder.
- Maintenance for the cylinder.

#### SOLAR CONTROLLER (→ FIG. 1, [4])

- Installing the controller.
- Operating the controller and the entire system.

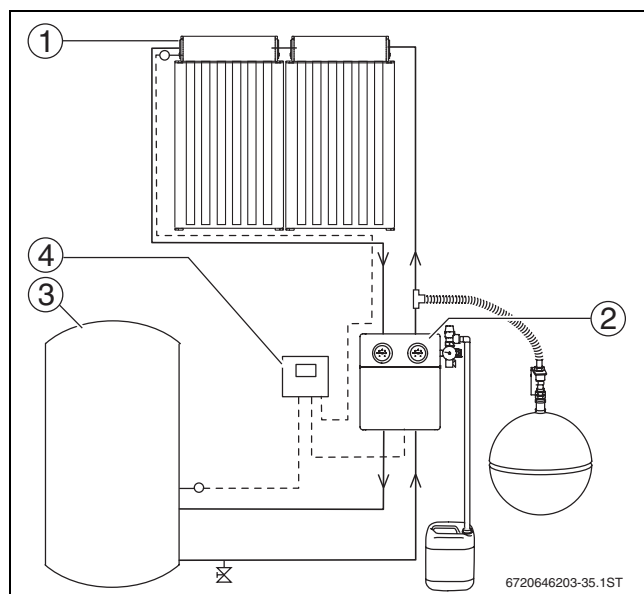

Fig. 1 Schematic diagram of a solar thermal system

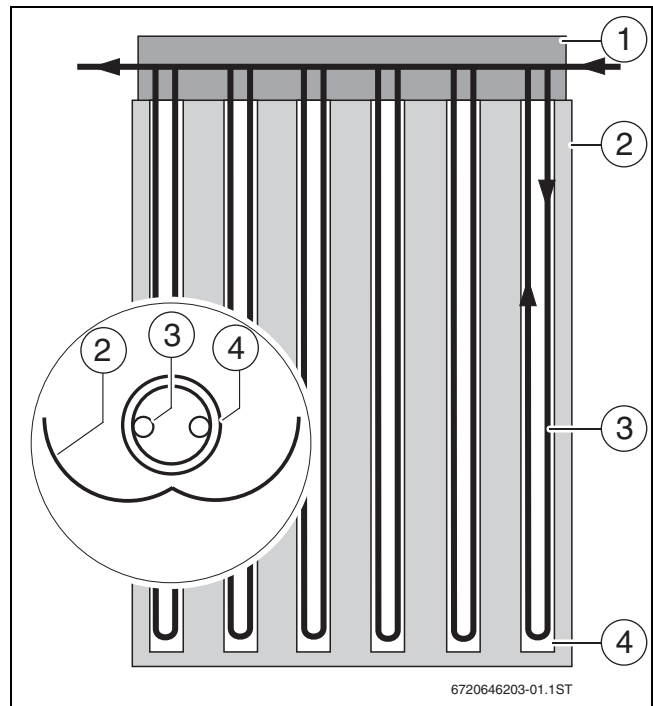

Fig. 2 Functional diagram of an evacuated tube collector, here: type Solar-Lux 6 = 6 tubes (type Solar-Lux 12 = 12 tubes)

- 1 Manifold
- 2 CPC mirror for optimum sunlight utilisation
- 3 Heat transfer medium tubes
- 4 Glass-glass evacuated tubes for optimum thermal insulation (It is possible to replace a tube without having to drain the system).

#### REGARDING THESE INSTRUCTIONS

The evacuated tube collector is referred to in its short form, collector, on the following pages. Roofing in the form of pantiles, roof tiles etc. is designated uniformly as roof tiles.

These instructions describe the installation of evacuated tube collectors (including their hydraulic connection) for the following roofing on pitched roofs:

- Pan tiles, plain tiles, tiles and slate shingles.

## 2.2 CORRECT USE

The installation set and the mounting brackets are intended only for the safe attachment of collectors to pitched roofs.

The collectors are for DHW heating and can be used to make a contribution to space heating in certain circumstances with specially designed systems. They may only be operated in combination with suitable solar controllers in intrinsically safe, sealed unvented solar thermal systems. These systems must be equipped with a suitable, adequately sized expansion vessel.

### PERMISSIBLE ROOF PITCH

The self-cleaning effect for the glass tubes and CPC mirror will only work if the roof has a pitch of at least 15°.

The maximum roof pitch is 65°.

### PERMISSIBLE LOADS

The installation set is suitable for the following:

- a standard snow load of 1.5 kN/m<sup>2</sup> or 2.0 kN/m<sup>2</sup> (→ Tab. 4, page 6)
- ▶ To determine the maximum wind speed, take into account the following factors:
  - the location of the solar thermal system,
  - the geographic elevation,
  - the topography
  - the height of the building.

If necessary, consult a building structural engineer.

### HEAT TRANSFER MEDIUM

To protect the collectors from frost and corrosion damage, they should be operated with the Tyfocor Glycol LS. Do not add any other heat transfer medium.

### OTHER APPLICABLE INSTRUCTIONS AND IMPORTANT NOTES

The installation and maintenance instructions for the solar pump station contain important information for using evacuated tube collectors in the solar thermal system. Please take particular note of the information on the following topics.

- Do not carry out brazing close to evacuated tube collectors.
- If system is used for central heating backup or covers more than 60% of DHW needs, install a pre-cooling vessel before the expansion vessel.
- Install the expansion vessel (EV) with a tee 20-30 cm above the solar pump station in the return pipework to the panel (→ Fig. 3).
- Do not use any forms of soft soldering with these collectors

- Use an electrical solar filling station to pressure fill with the heat transfer medium Tyfocor LS to purge and fill the system (do not use water because the collectors cannot be drained). This means that there is no need to have an air vent valve up on the roof.
- For the required expansion vessel pre-charge pressure setting and the operating pressure and flow rate settings for the vacuum tube collector system, please see the chapter entitled "Final activities" (→ page 24).

In addition to the notes from the solar pump station instructions, please also observe the following:

- The distance between the solar pump station (Expansion vessel connection) and the bottom edge of the collector array must be at least 2 m (→ Fig. 3).
- The minimum pipe length between the solar pump station (expansion vessel connection) and the collector array must be at least 5 m. For systems utilising more than 18 tubes, a minimum of 10 metres is required.

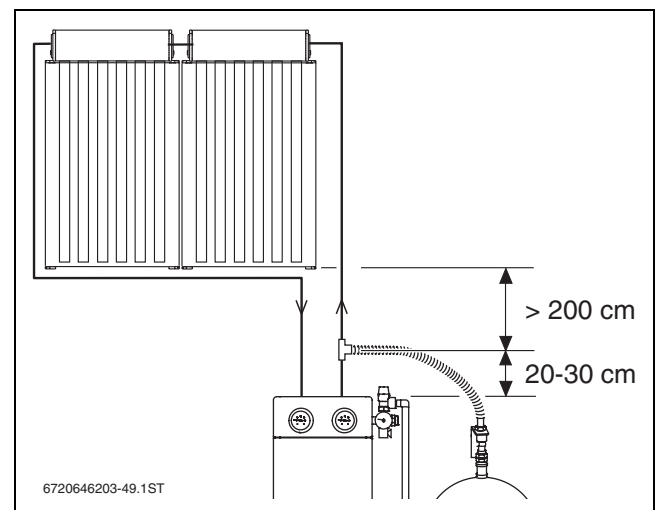

Fig. 3

## 2.3 EU DECLARATION OF CONFORMITY

This product conforms in design and operation to the European Directives and the supplementary national requirements. Its conformity is demonstrated by the CE designation.

The Declaration of Conformity can be requested from the manufacturer (see the back cover for the address).

## 2.4 STANDARD DELIVERY

- Check that the delivered material is complete and undamaged.

### 2.4.1 ANGLE SECTION FRAME (FLAT ROOF, WALLS)

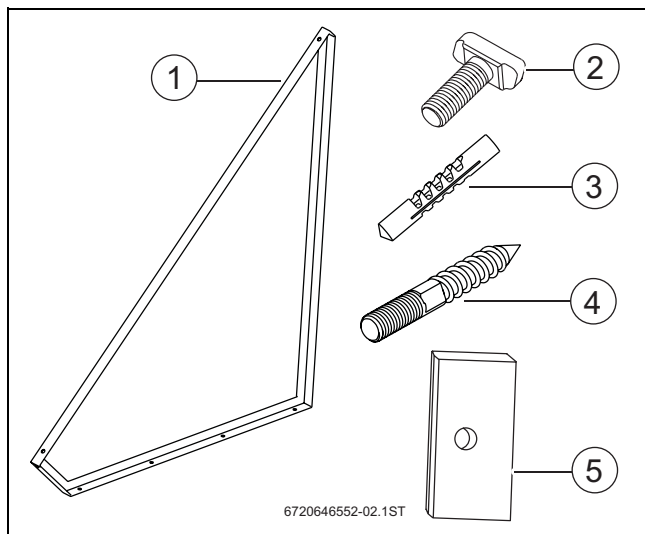

Fig. 4 Standard delivery, angle section frame and accessories

Item 1	Angle section frame 45° or 30/60°	2 x
Item 2	Hammer head bolt set (incl. washer and nut M10)	4 x
Item 3	Rawl plug 12 mm	8 x
Item 4	Double ended screw set (incl. washer and nut M10)	8 x
Item 5	Support plate 100 x 30 mm	2 x

Tab. 2 Standard delivery, angle section frame for one collector

### 2.4.2 MOUNTING BRACKET (WALL, 90°)

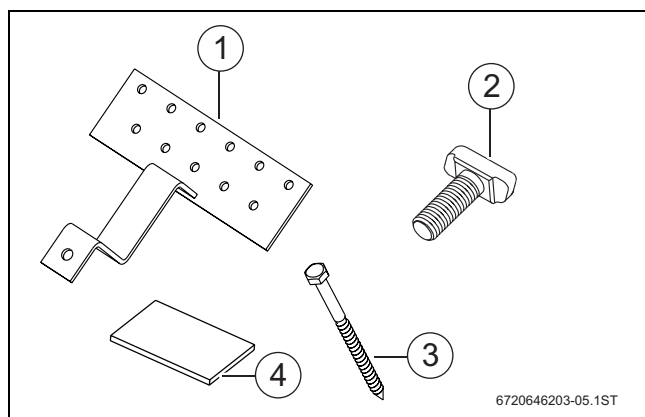

Fig. 5 Standard delivery, mounting bracket

Item 1	Mounting bracket	4 x
Item 2	Hammer head bolt set (incl. washer and nut M10)	4 x
Item 3	Screw 8 x 120 <sup>1)</sup>	12 x
Item 4	Wooden support 100 x 150 x 8 mm <sup>1)</sup>	12 x

Tab. 3 Standard delivery, mounting bracket and accessories

1) Not required.

### 2.4.3 INSTALLATION SET

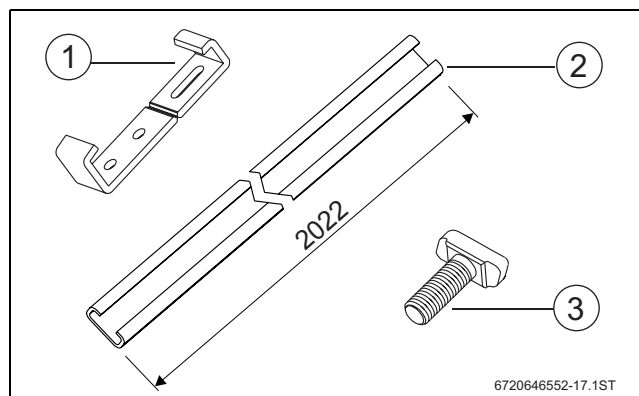

Fig. 6 Standard delivery, rails and accessories

Item 1	Clamping bracket top/bottom	2 x
Item 2	Rail	2 x
Item 3	Hammer head bolt set (incl. washer and nut M10)	6 x

Tab. 4 Standard delivery, installation set for one collector

### 2.4.4 CONNECTION SET (HYDRAULIC CONNECTION)

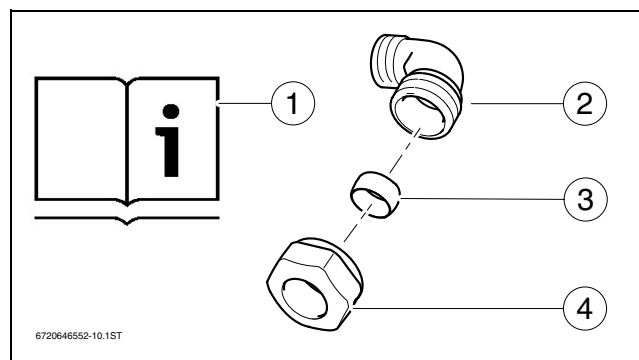

Fig. 7 Standard delivery, connection set

Item 1	Installation instruction	1 x
Item 2	Angle	2 x
Item 3	15 mm olive	2 x
Item 4	Union nut	2 x

Tab. 5 Connection set

2.4.5 COLLECTOR

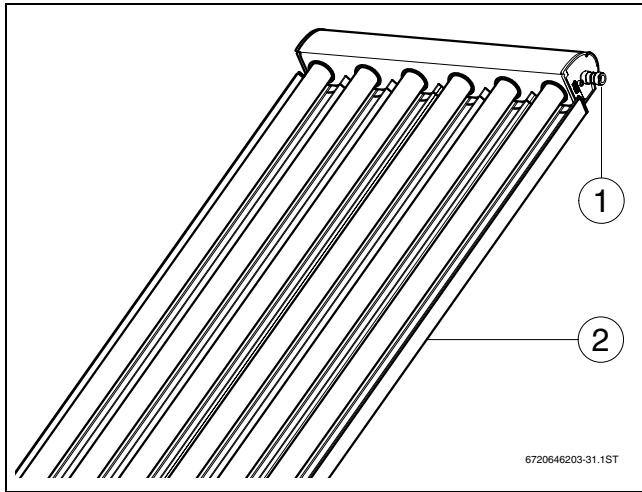

Fig. 8 Collector with male connection

Item 1	Male connection as joint between the collectors	1 x
Item 2	Collector Solar-Lux 6/12 comprising: evacuated tubes, CPC mirror, header	1 x

Tab. 6

2.5 TYPE PLATE

The type plate is fitted to the header and includes all important details in the form of symbols.

Symbol	Meaning	Explanation
$A_G$	area <sub>gross</sub>	Gross area
$A_a$	area <sub>aperture</sub>	projected mirror surface
$A_A$	area <sub>absorber</sub>	Absorber area
Dimensions		Dimensions
$V_f$	volume <sub>fluid</sub>	Collector contents
$m$	mass	Weight
$t_{stg}$	temperature <sub>stagnation</sub>	Idle temperature, max.
$p_{max}$	pressure <sub>maximum</sub>	Max. operating pressure
$p_{pr}$	pressure <sub>proof</sub>	Test pressure
$y_{prod}$	year <sub>production</sub>	Year of manufacture

Tab. 7 Type plate details

2.6 SPECIFICATION

	Solar-Lux 6	Solar-Lux 12
Certificates		
Width	0.70 m	1.40 m
Depth	0.10 m	0.10 m
Length	2.06 m	2.06 m
Collector connection, flow and return	15 mm	15 mm
Absorber capacity	0.97 l	2.12 l
Aperture area	1.28 m <sup>2</sup>	2.57 m <sup>2</sup>
Absorber area	1.29 m <sup>2</sup>	2.58 m <sup>2</sup>
Gross area	1.45 m <sup>2</sup>	2.86 m <sup>2</sup>
Net weight	24 kg	43 kg
permissible operating pressure collector ( $p_{max}$ )	10 bar	10 bar
Test pressure ( $p_{pr}$ )	13 bar	13 bar
Stagnation temperature	301 °C	301 °C
Number of glass tubes	6	12
Glass tube: tube length / external $\varnothing$ / internal $\varnothing$	1920 mm / 47 mm / 37 mm	

Tab. 8

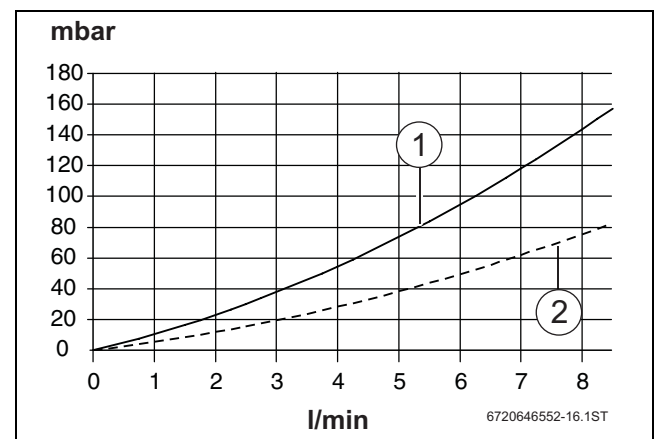

Fig. 9 Collector pressure drop

- 1 Pressure drop for Solar-Lux 12
- 2 Pressure drop for Solar-Lux 6

### **3 REGULATIONS**

- ▶ Comply with all standards and guidelines applicable to the installation and operation of the system in your country and region.

These include, but are not limited to:

- The Health and Safety at Work Act 1974.
- Control of substances hazardous to health regulations (COSHH) 1994
- The pressure equipment regulations 1999
- Construction (Design and Management) Regulation (CDM) 2007
- The Work at Height Regulations 2005
- Manual Handling Operations Regulations 1992
- The Lifting Operations and Lifting Equipment Regulations (LOLER) 1999
- Reporting of injuries, diseases or dangerous occurrences regulations (RIDDOR) 1995
- Confined spaces regulations 1997
- Personal protective equipment at work regulations 1992
- Electricity at work regulations 1989
- Provision and uses of work equipment regulations (PUWER) 1998
- BS 6795:1986 Code of practice for solar heating systems for swimming pools for swimming pool.
- BS5918: A code of practice for the installation of DSHW systems for domestic hot water
- BS5546: 2000 Specification for installation of hot water supplies for domestic purposes, using gas-fired appliances of rated input not exceeding 70 kW.
- BS6700: 2006 Specification for design, installation, testing and maintenance, of servicing supplying water for domestic use within buildings and their curtilages.
- EN 12976: Thermal solar heating system and their components (prefabricated systems).
- ENV 12977: Thermal solar heating system and their components (bespoke systems).
- BS 6920: Suitability of non-metallic products for use in contact with water intended for human consumption with regards to their effect on the quality of water
- BSEN 12831:2003: Heating systems in buildings. Methods for calculation of the design heat load
- BS 8000-15: 1990: Workmanship on building sites. Code of practice for hot and cold water services (domestic scale)

## 4 BEFORE INSTALLATION

### 4.1 DETERMINING THE ANGLE OF INCIDENCE OF THE COLLECTORS

The collectors' angle of incidence depends on the required area of application. Select the correct angle of incidence to safeguard the optimum annual yield.

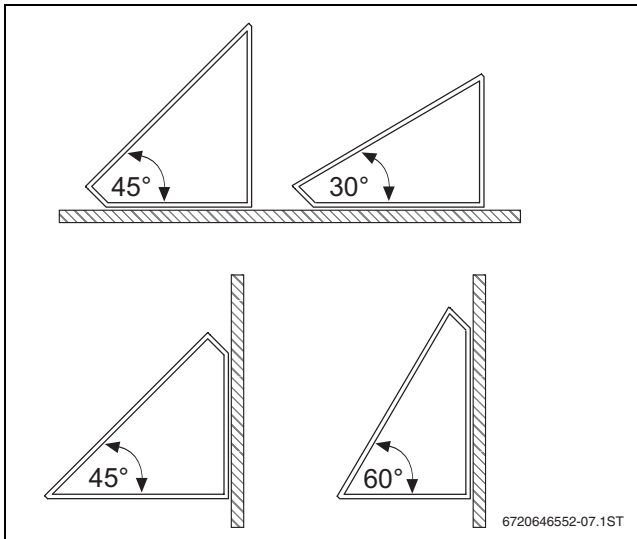

Fig. 10 Possible angle of incidence of the angle section frames and their application (flat roof or wall)

Application area	Angle of incidence $\alpha$
Domestic hot water (DHW)	30°, 45°
DHW + central heating backup	45°, 60°
DHW + swimming pool	30°, 45°
DHW + central heating backup + swimming pool	45°, 60°

Tab. 9 Area of application and angle of incidence



The angle of incidence is 90° if you use mounting brackets for wall mounting.

### 4.2 DETERMINING SPACE REQUIREMENTS

Take account of the details concerning the optimum arrangement of the collectors and the prevention of shading ( $\rightarrow$  Chapter 4.4).

#### 4.2.1 CLEARANCE BETWEEN COLLECTOR ROWS

The minimum clearance between the collector rows on a flat roof is determined by the angle of incidence of the collector.

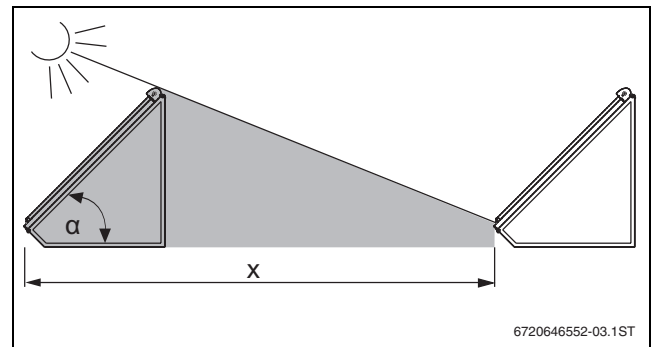

Fig. 11 Illustration of shading, subject to the sun at its lowest level

Angle of incidence $\alpha$	Dim. x
30°	3 m
45°	5.5 m

Tab. 10

#### 4.2.2 SPACE REQUIREMENT FOR THE COLLECTOR ARRAY

The space requirement is determined by the installation area of the collector array ( $\rightarrow$  Fig. 14). When siting the collector array ensure that the minimum clearances from the roof edge are maintained ( $\rightarrow$  Fig. 12 and 13).



**WARNING:** Risk of injury from collectors that cannot resist peak wind.

► Maintain the minimum clearance to the edge area.

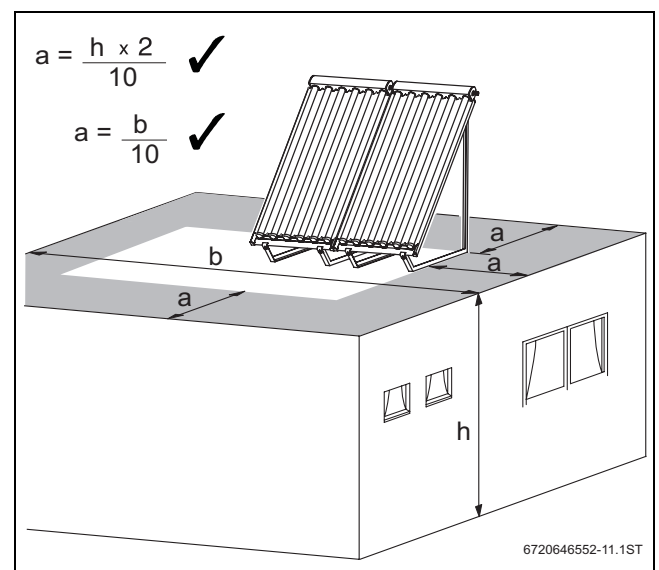

Fig. 12 Minimum clearance from the roof edge (dim. a); both formulae can be applied

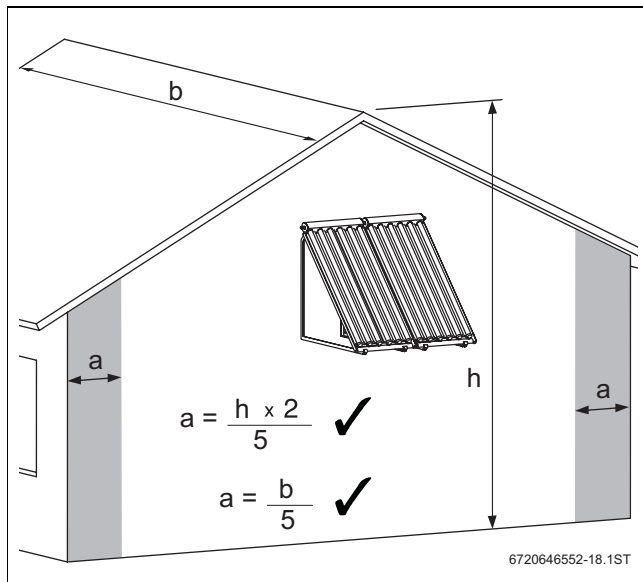

Fig. 13 Minimum clearance towards the lateral edge (dim. a) when installing collectors on walls; both formulae can be applied

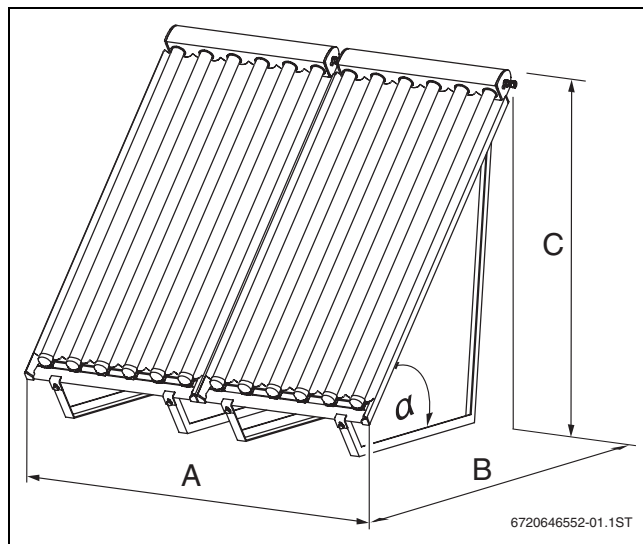

Fig. 14 Collector array site

Number of collectors	Dim. A Solar-Lux 6	Dim. A Solar-Lux 12
1	0.70 m	1.40 m
2	1.40 m	2.80 m
3	2.10 m	4.20 m
4	2.80 m	--
5	3.50 m	--
6	4.20 m	--

Tab. 11

Angle of incidence $\alpha$	Dim. B	Dim. C
30°	1.85 m	1.22 m
45°	1.49 m	1.49 m
60°	1.22 m	1.85 m
90° <sup>1)</sup>	--	2.06 m

Tab. 12 Dimensions for flat roof and wall installation

1) Installation with mounting brackets in place of angle section frames

### 4.3 PLANNING THE HYDRAULIC CONNECTION

Before you install the collectors you will need to know how you can arrange the collectors.



The collector sensor [1] must be fitted in the collector connected to the flow pipe [2].

#### MAX. NUMBER OF COLLECTORS PER ROW:

- Solar-Lux 6: 6 collectors
- Solar-Lux 12: 3 collectors

#### THE FOLLOWING SHOWS TWO EXAMPLES OF HYDRAULIC LAYOUTS FOR EVACUATED TUBE COLLECTORS:

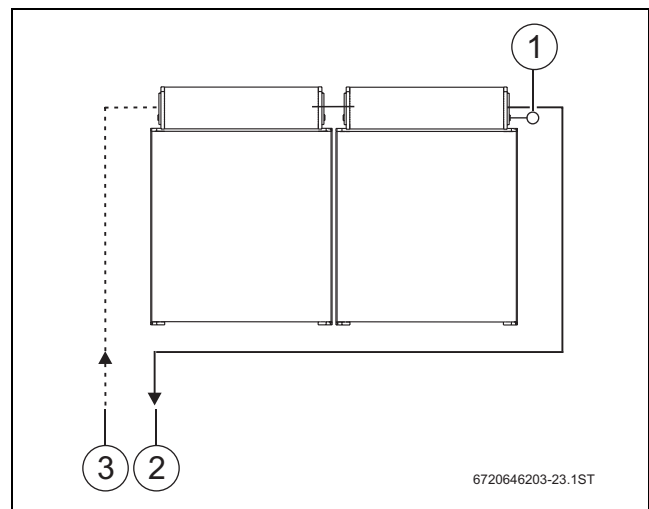

Fig. 15 Single row connection. Here: flow on the l.h. side

- 1 Collector sensor (always on the flow side)
- 2 Flow pipe (towards the cylinder)
- 3 Return pipe (from the cylinder)

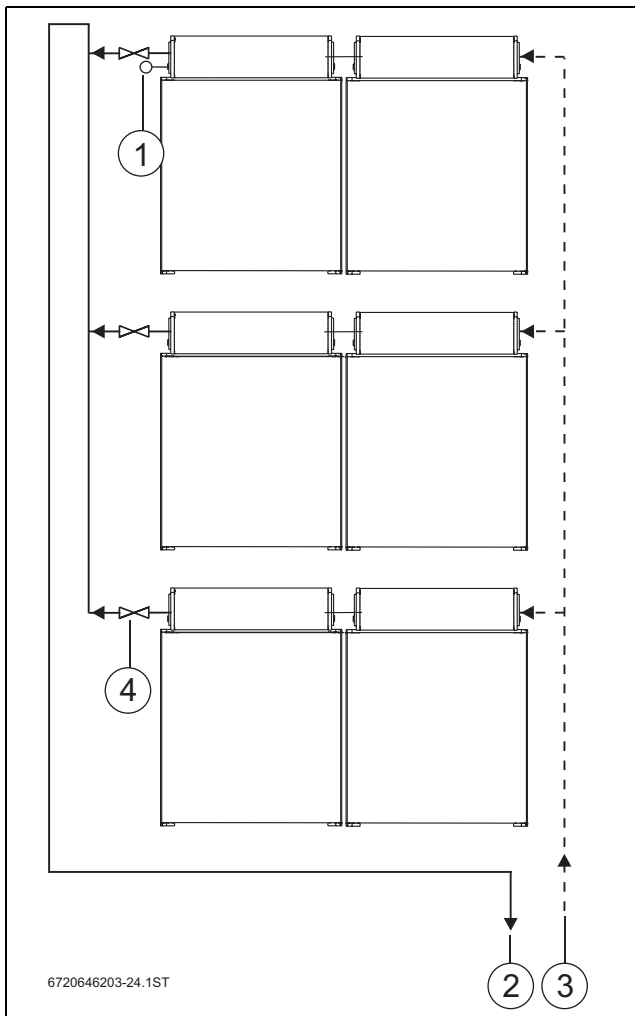

Fig. 16 Triple row connection (with shut-off valve).  
Here: flow on the l.h. side

- 1 Collector sensor (always on the flow side)
- 2 Flow pipe (towards the cylinder)
- 3 Return pipe (from the cylinder)
- 4 Shut-off valve (accessory)

#### 4.4 OBSERVE GENERAL INFORMATION



We recommend that you engage the services of a roofing contractor, as they are experienced in working on roofs and will be aware of the risk of falling.

- Obtain information about on-site conditions and local regulations.
- Always install collectors with their header at the top (→ Fig. 17).

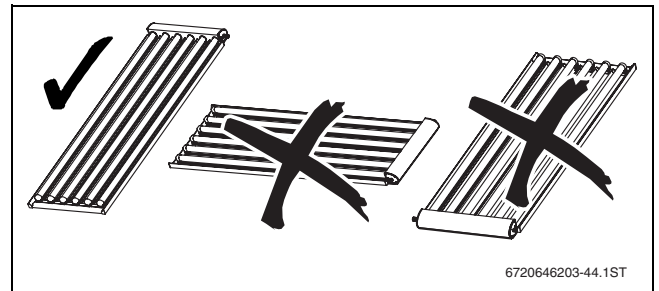

Fig. 17 Permissible installation orientation

- Align the collector array towards the south, where possible (→ Fig. 18).
- Arrange the collectors in a visually appealing way on the roof, for example, so that the collector array is in line with windows and doors (→ Fig. 18). However, observe the minimum clearances towards the edge of the roof (→ Fig. 12).
- Prevent shading of the collector array through adjacent buildings, trees etc.

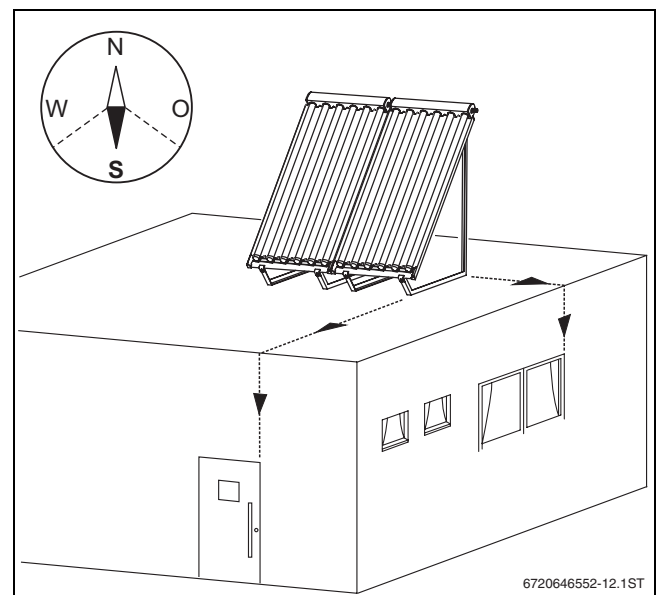

Fig. 18 Example: Adapt the collector array as flat roof installation to the shape of the building

#### 4.5 CONCRETE SLABS FOR STABILISING

On flat roofs, every angle section frame is stabilised with two concrete slabs to be provided on site. For the required minimum weight for each concrete slab, see the table. To prevent the roof skin from being damaged, underlay each concrete slab with protective mats (→ Fig. 19 [1]).



Observe the additional load on the roof. If required, consult a structural engineer.

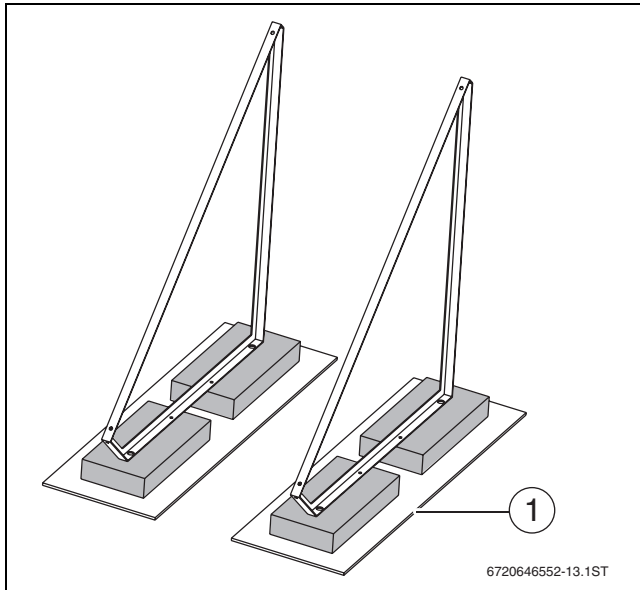

Fig. 19 Stabilisation of the angle section frame



**NOTE:** Collector damage through inadequate stabilisation.

- ▶ Observe the minimum weight of the concrete slabs for stabilising the angle section frame.

Wind speed	Stagnation pressure	Minimum weight per concrete slab (2 pce. per angle section frame)	
		Solar-Lux 6	Solar-Lux 12
up to 102 km/h	0.5 kN/m <sup>2</sup>	47.5 kg	95 kg
up to 129 km/h	0.8 kN/m <sup>2</sup>	77.5 kg	155 kg

Tab. 13

#### 4.6 REQUIRED TOOLS AND ACCESSORIES

- Concrete slabs (→ Chapter 4.5)
- Protective building mat (underlay for concrete slabs)
- Spanner sizes SW 8, 17, 19, 22, 24, 30
- Masonry drill Ø 12 mm (for concrete slabs)
- Hammer and Phillips screwdriver (for connection set, accessories)
- Material for pipe insulation

#### 4.7 LIGHTNING PROTECTION

The requirement for lightning protection can differ from region to region.

- ▶ Check regional regulations as to whether a lightning protection system is required.

Lightning protection is frequently required for buildings higher than 20 m, for example.

Lightning protection should be installed by a qualified electrician.

Where there is a lightning protection system installed, check the inclusion of the solar thermal system into this system.

#### 4.8 INSTALLATION SEQUENCE

For the installation of collectors on the roof or on walls, take the following installation steps in the order described:

1. Fit the angle section frames or mounting brackets.
2. Fit the rails and clamping brackets
3. Fit the collectors and collector sensors.
4. Connect the pipework to the collector.

## 5 HANDLING

The collectors and the installation materials are heavy and difficult to handle. Please observe the following notes, since working on the roof can also be dangerous.



**DANGER:** Risk to life through falls or falling parts!

- ▶ Do not use a ladder to move components to the roof because the installation material and collectors are heavy and can be difficult to handle.
- ▶ Take appropriate action to prevent accidents during all work on roofs.
- ▶ Take precautions against a possible fall.
- ▶ Always wear personal protective clothing and safety equipment.
- ▶ At least 2 people must carry out installation on the roof.
- ▶ During transport, secure the collectors and installation material to prevent them falling.
- ▶ After completing installation, check that the installation set and collectors are securely positioned.



**NOTE:** Collector damage through transport. We recommend transporting the collector to the roof in its transportation packaging.



**WARNING:** Risk of injury from broken glass.

- ▶ When handling the collectors, always wear protective gloves and goggles.

- ▶ The belt loops at the top of the collector are for assistance in handling the unit.



**DANGER:** Risk to life through inadequately secured collectors during transport.

- ▶ Make sure that the collectors are securely fastened during transportation.

- ▶ To make it easier to transport the collectors and the installation material, use the following aids with sufficient load-bearing capacity:
  - Mobile hoist or crane
  - Lifting belt
  - Roofing ladder or equipment for sweeping chimneys
  - Scaffolding
- ▶ Dispose of transportation packaging using the most environmentally friendly method of recycling.

## 6 FITTING THE ANGLE SECTION FRAMES

The angle section frames can be fitted on flat roofs or on walls.

**NOTE:** Collector damage through incorrectly fitted angle section frames.

- ▶ Maintain the clearance between the angle section frames (→ Fig. 20).
- ▶ Fit the angle section frames on site on concrete slabs or walls with adequate load bearing capacity.

### 6.1 FITTING THE ANGLE SECTION FRAME ON THE FLAT ROOF

- ▶ Check the roof skin and remedy any damage.
- ▶ To safeguard the collectors' stability, remove any grit or similar material.

**NOTE:** Roof leaks through missing protective mats.

- ▶ To prevent the sealing membrane of the roof being damaged, underlay the concrete slabs with conventional protective mats (→ Fig. 20 [1]).

- ▶ Align the concrete slabs in accordance with the dimensions and locations of the drilled holes (→ Fig. 20, Tab. 14).

Angle of incidence $\alpha$	Dim. D	Dim. E	Dim. G
30°	Solar-Lux 6: 450	408	408
	Solar-Lux 12: 800		
45°	Solar-Lux 6: 450	303	305
	Solar-Lux 12: 800		

Tab. 14 Hole centres (dim. in mm)

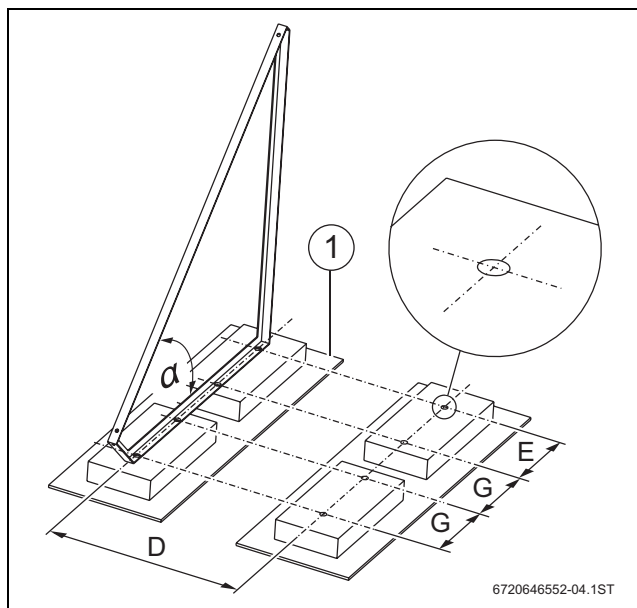

Fig. 20

- ▶ Secure the angle section frame (→ Fig. 21):
  - Drill  $\varnothing$  12 mm holes in the concrete slabs.
  - Inset rawl plugs [2].
  - Secure each angle section frame with four double ended screws [1], washers and nuts M10 to the concrete slabs (use SW8 and 17 spanners). The minimum length of thread engagement for the double ended screws is 50 mm.

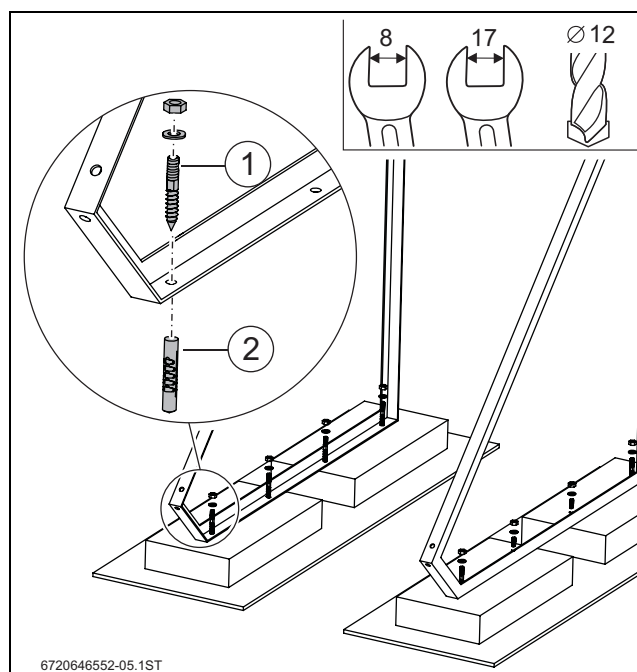

Fig. 21

## 6.2 FITTING THE ANGLE SECTION FRAME ON THE WALL

The angle section frame enables the collectors to be fitted on walls.

**!** **DANGER:** Risk to life due to falling collectors

- ▶ Install only on a sealed windproof outside wall.
- ▶ Never modify the angle section frames.
- ▶ Before installing the collector, have a structural engineer check the load bearing capacity of the fixing wall (i.e. of the wall substrate).
- ▶ Only use fasteners and rawl plugs suitable for the relevant wall structure. Check whether the rawl plugs supplied are suitable for the wall structure.
- ▶ Never insert objects into the gaps between the angle section frames.
- ▶ Never attach decorative covers or similar to the angle section frames.

**i** In order to enable the removal of the tubes during servicing, maintain a clearance of 0.9 m below the collector at an angle of incidence of 60°.

▶ Transfer the positions of holes to be drilled onto the wall (→ Fig. 22, Tab. 14).

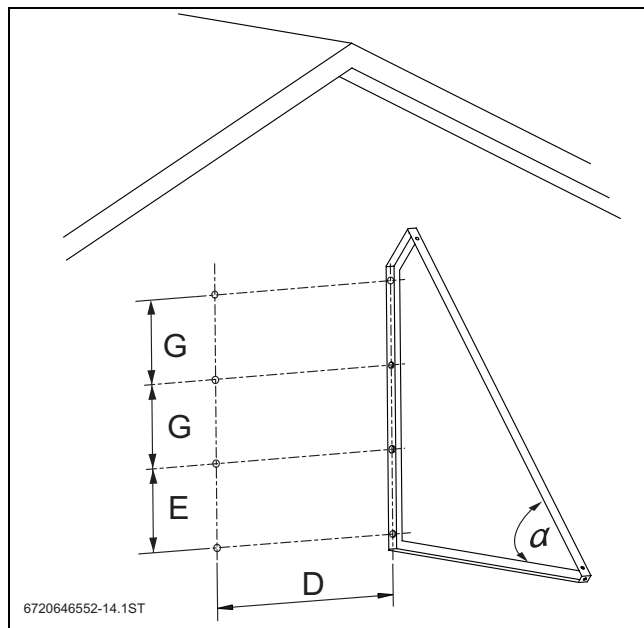

Fig. 22 Hole positions for the angle section frames

Angle of incidence $\alpha$	Dim. D	Dim. E	Dim. G
60°	Solar-Lux 6: 450	408	408
	Solar-Lux 12: 800		
45°	Solar-Lux 6: 450	303	305
	Solar-Lux 12: 800		

Tab. 15 Hole centres (dim. in mm)

**!** **DANGER:** Risk through falling collectors.

- ▶ At the top fixing point, install the support plate in place of the washer (→ Fig. 23 [3]).

- ▶ Securing the angle section frame:
  - Drill holes.
  - Inset rawl plugs [1].
  - At the top fixing point of every angle section frame, insert the support plate supplied [3] in place of the washer [4].
  - Secure each angle section frame with four double ended screws [2] to the wall (use SW8 and 17 spanners)

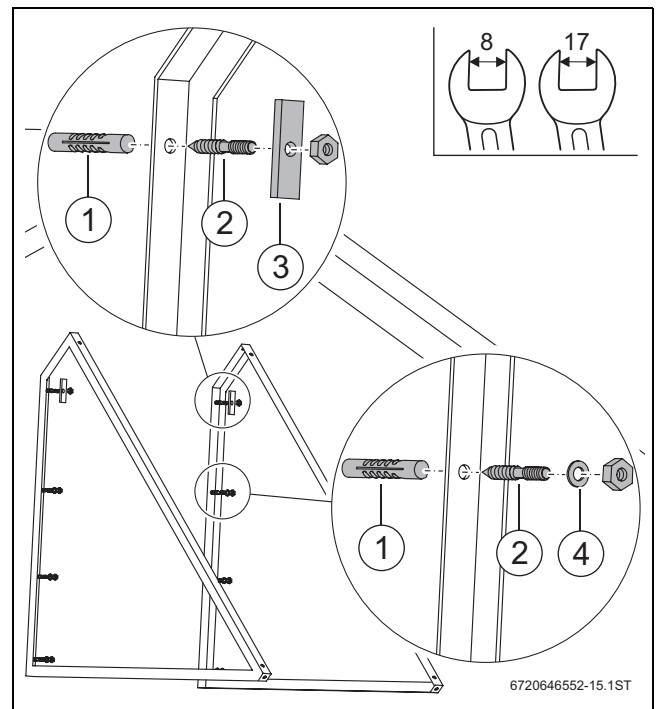

Fig. 23

- 1 Rawl plug
- 2 Double ended screw
- 3 Support plate 100 x 30 mm
- 4 Washer

## 7 FITTING THE MOUNTING BRACKET

You can secure the collectors vertically on the wall using the mounting brackets.

### PREASSEMBLE THE MOUNTING BRACKET ON THE GROUND

To make the installation on the wall easier, we recommend the preassembly of all fittings to the mounting brackets on the ground.

- ▶ Secure the hammer head bolt with washer and M10 nut on the mounting bracket.

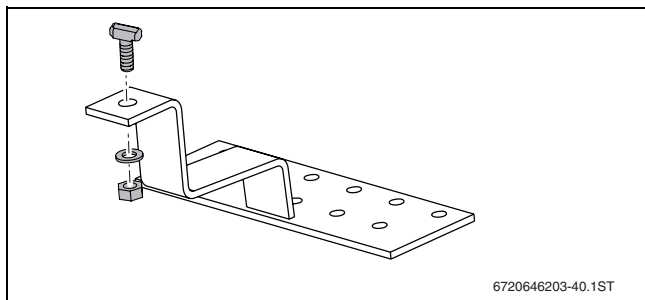

Fig. 24 Pre-fitting the hammer head bolts on the ground

### FITTING THE MOUNTING BRACKET ON THE WALL



**DANGER:** Risk to life due to falling collectors.

- ▶ Check the screws 8 x 120 mm for suitability for the installation wall. Only use fasteners and rawl plugs suitable for the relevant wall structure.
- ▶ Never modify the rails or the mounting brackets.
- ▶ Before installing the collector, have a structural engineer check the load bearing capacity of the fixing wall (i.e. of the wall substrate).



In order to enable the removal of the tubes during servicing, maintain a suitable clearance below the collectors subject to the collector length.

- ▶ Transfer the positions of mounting brackets onto the wall (→ Fig. 25, Tab. 16).

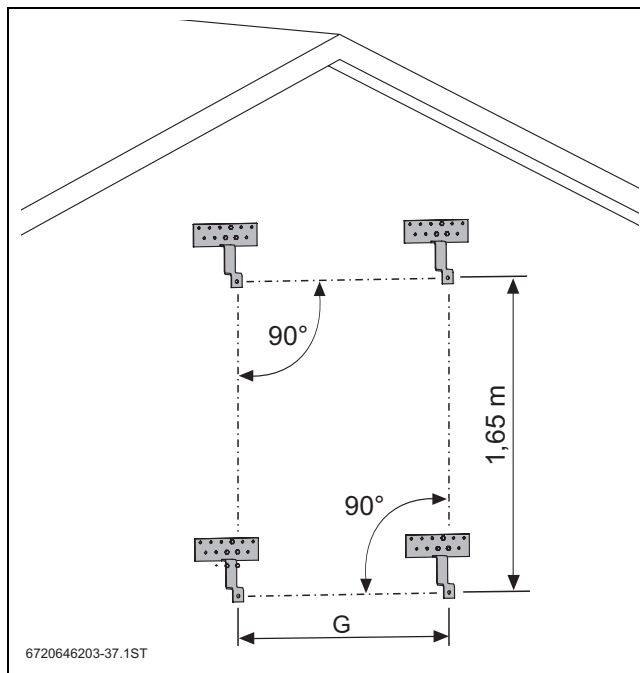

Fig. 25 Positions of mounting brackets

	Solar-Lux 6	Solar-Lux 12
Dim. G	0.45 m	0.80 m

Tab. 16 Hole centres

- ▶ Securing the mounting brackets (→ Fig. 26):
  - Drill holes.
  - Inserting rawl plugs [2] on site.
  - Secure mounting bracket [3] with on-site screws [1] to the wall.

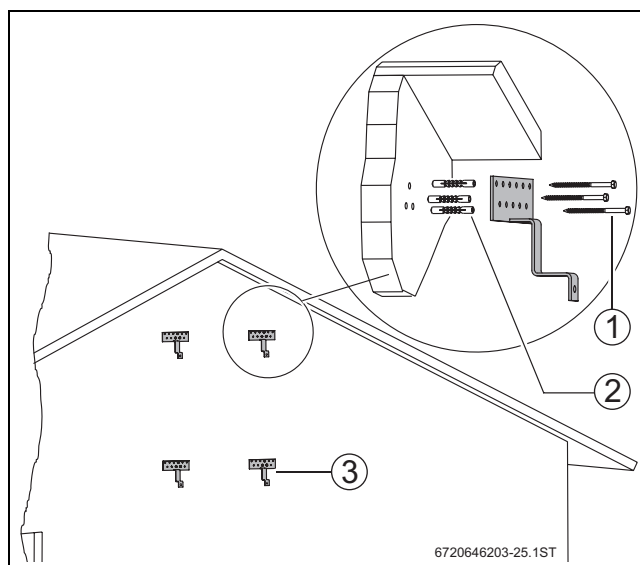

Fig. 26 Securing the mounting brackets

## 8 RAIL INSTALLATION

The rails and clamping brackets are used to connect the collector with the roof/wall.



Make sure when installing the rails that they protrude equally at the top and bottom (→ Fig. 27 and 28).

► Align the rails accurately with a line.

Secure the top clamping brackets at the collector and rail only after the collector installation.

### 8.1 FITTING THE RAILS ON THE ANGLE SECTION FRAMES

1. Separate the top and bottom clamping brackets [1] and [2] at their predetermined breaking point.
2. In order to secure the clamping brackets at the bottom, slide the hammer head bolts onto the rails as far as they will go. Then tighten them (use a SW17 spanner).  
Check the hammer head bolt [3] is seated correctly.
3. Position the rails on the angle section frame and secure with the hammer head bolts (use SW17 spanner).

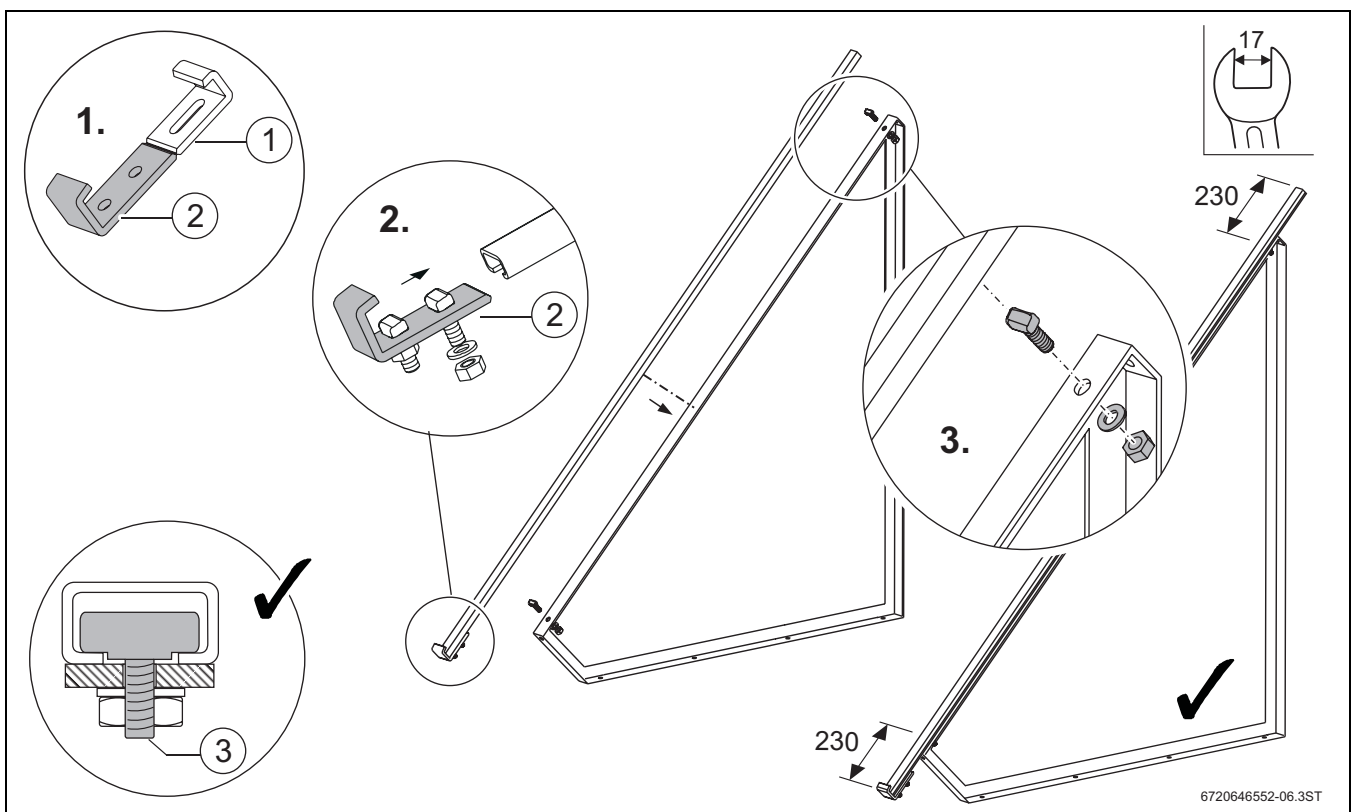

Fig. 27 Fitting the clamping brackets and rails; here: flat roof supports 45° (the rails and clamping brackets are fitted similarly on walls)

## 8.2 FITTING THE RAILS ON MOUNTING BRACKETS

1. Separate the top and bottom clamping brackets [1] and [2] at their predetermined breaking point.
2. In order to secure the clamping brackets at the bottom, slide the hammer head bolts onto the rails as far as they will go. Then tighten them (use a SW17 spanner).
- Check the hammer head bolt [4] is seated correctly.

3. Position the rails [3] on the mounting bracket and secure with the hammer head bolts (use SW17 spanner).
- Align the rails accurately.

Secure the top clamping brackets at the collector and rail only after the collector installation.

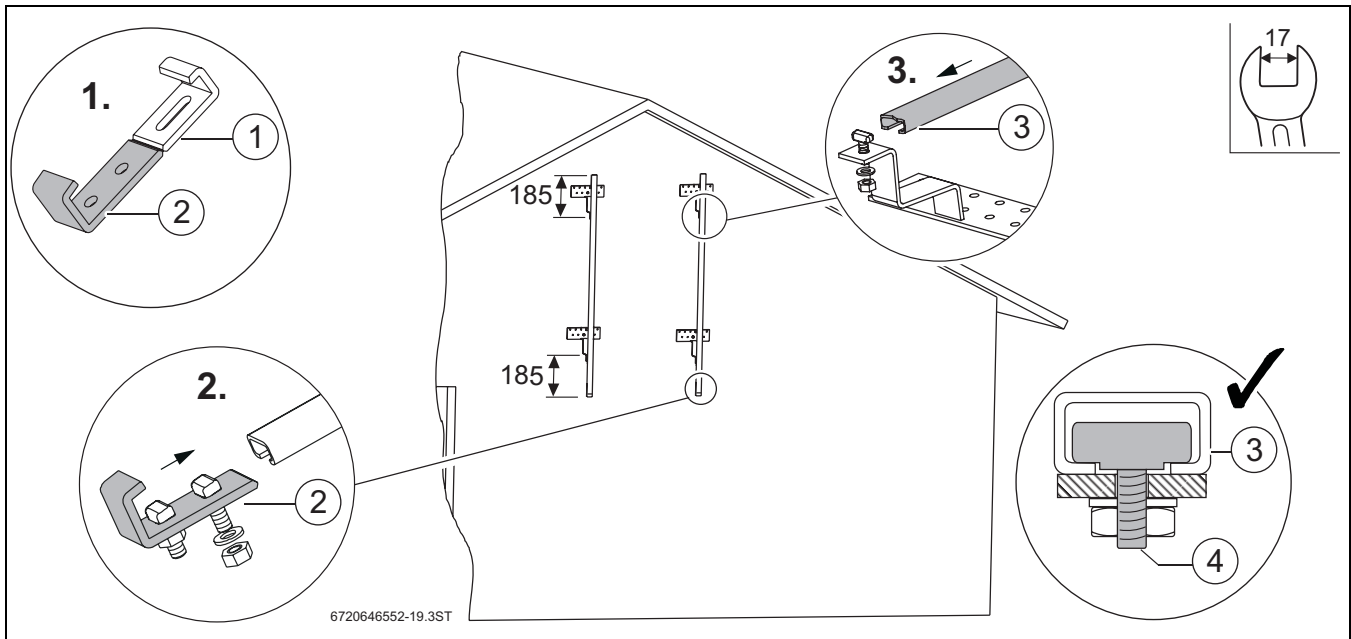

Fig. 28 Fit the clamping brackets and rails

- 1 Top clamping bracket
- 2 Bottom clamping bracket
- 3 Rail
- 4 Hammer head bolt

## 9 INSTALLING THE COLLECTORS

Once the mounting brackets and the rails with the retaining clips have been installed, the collectors can be fastened.

**DANGER:** Risk to life through falling parts!

- ▶ During installation, secure the collectors to prevent them falling.

**WARNING:** Risk of injury from broken glass.

- ▶ When handling the collectors, always wear protective gloves and goggles.

**NOTE:** Collector damage from evaporation in the solar circuit.

- ▶ Leave the sun protection film on the collector until the collector has been purged and filled. However, it must not be exposed to the elements for more than 4 weeks.
- ▶ Fit a suitable sun protection cover for longer periods of time.
- ▶ Please observe all guidelines for working at height.

### 9.1 INSTALLING THE FIRST COLLECTOR

Align the first collector in such a way that during installation all collectors have the same overhang over the rails to the right and left.

- ▶ Place the packed collector on the rails.
- ▶ Open the packaging at the bottom. The collector can now slide into the lower retaining clips [3]. This clip must fully grip the collector profile.
- ▶ For the 1300 mm horizontal rail, push the outer edge of the collector to the middle of the rail. Once all the collectors are installed, the overhang on the sides will be the same.

Wait to tighten the upper retaining clips until the collectors are screwed to each other.

- ▶ Install the upper retaining clips [1 or 2] the same way as the lower retaining clips [3].

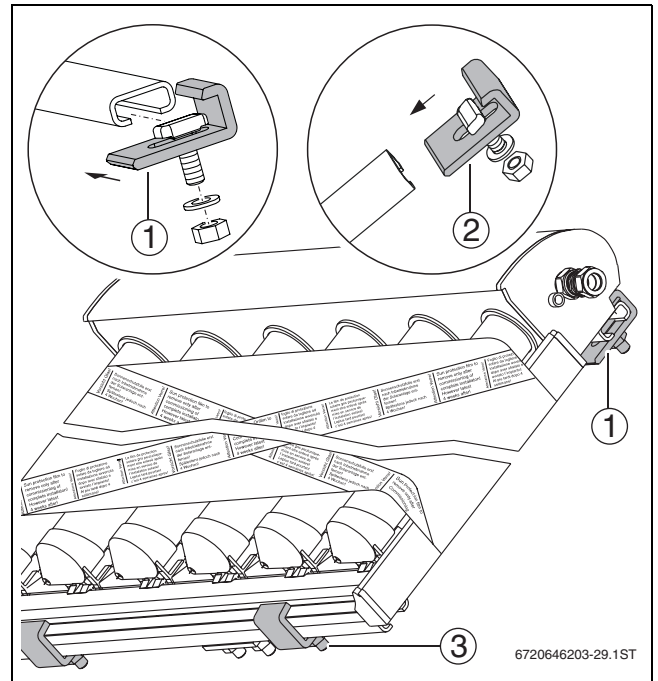

Fig. 29 Collector fastened to the horizontal rails

- 1 Upper retaining clip for horizontal rail
- 2 Upper retaining clip if only vertical rails are available
- 3 Lower retaining clip

## 9.2 INSTALLING THE SECOND COLLECTOR

The connection fitting (→ Fig. 30) on the right-hand side of the collector connects the two collectors.

- ▶ Place the second collector on the rails and push it towards the collector that is already installed.
- ▶ Align the collectors on the rails in such a way that the overhang on the right and left is the same.

**NOTE:** Collector damage through over-tightening.

- ▶ Hold the connection nipple [4] using a size SW22 spanner.
- ▶ Tighten the nuts [2] using a size SW24 spanner.

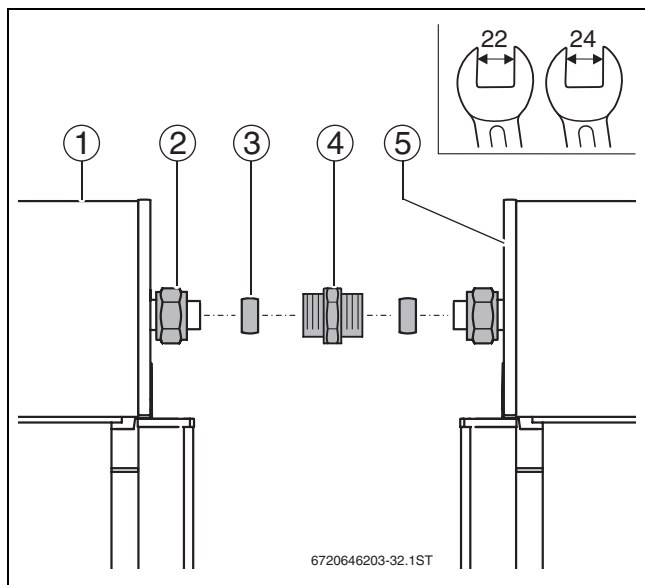

Fig. 30 Connecting the collectors with each other hydraulically

- 1 Left-hand collector
- 2 Union nut (already assembled)
- 3 Olive (already assembled)
- 4 1/2 " connection nipple
- 5 Right-hand collector

- ▶ Install all other connectors the same way.
- ▶ Tighten upper retaining clips with a size SW17 spanner (→ Fig. 29).

**CAUTION:** Risk of scalding from fittings that have not been tightened.

- ▶ Check that all fittings have been tightened.

## 9.3 INSTALLING THE COLLECTOR SENSOR

The collector sensor is supplied with the solar pump station, control or separately as part of a first fix kit and must be installed in the collector connected to the (hot) flow pipe (→ page 10, 11).

**NOTE:** System damage through faulty sensor cable.

- ▶ Protect the cable from possible damage.

**i** The collector sensor must be correctly installed to ensure proper operation of the solar thermal system.

- ▶ Push the collector sensor [1] 90 mm into the sensor well (to the end-stop).

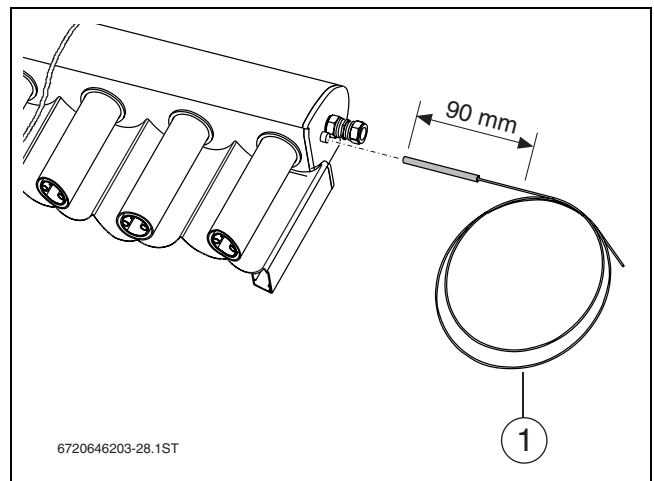

Fig. 31 Installing the collector sensor

## 9.4 INSTALLING THE CONNECTION COVER SET (ACCESSORY)

To improve the appearance of the area between two connectors, you can install the connection cover set as an accessory.

### STANDARD DELIVERY

- 1 x insulation piece (45 mm wide, 19 mm thick) with self-adhesive closure
- 1 x cover (70 mm wide)
- 1 x securing bar (8 x 10 x 80 mm) with screw (4.2 x 19 mm)
- 2 x connection plug with metal pin

### TOOL

Screwdriver (Phillips), hammer

### INSTALLATION

The collectors must be exactly aligned prior to installation.

1. Place the insulation piece over the fitting from below and seal using the self-adhesive tab.
2. Push the cover onto the insulation.
3. Fasten the cover to the back side of the collector with the securing bar.

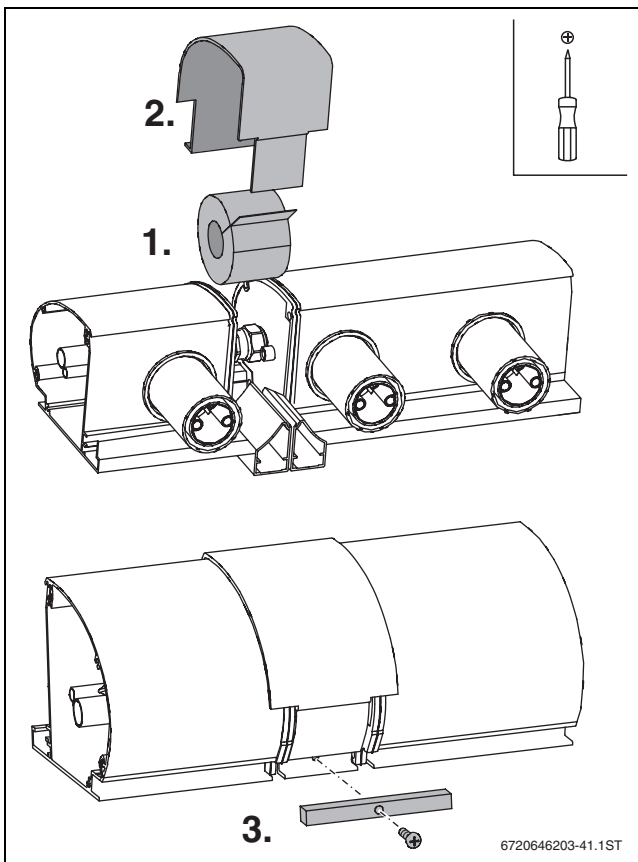

Fig. 32 Top of collector at manifold: installing insulation piece and cover

The new connection plugs hold together the two collector frames, maintaining the correct dimensions.

1. Remove the original plugs from the collector frame profiles.
2. Inserting the new connection plugs into the profiles.
3. Drive the metal pin into the plug with the hammer.

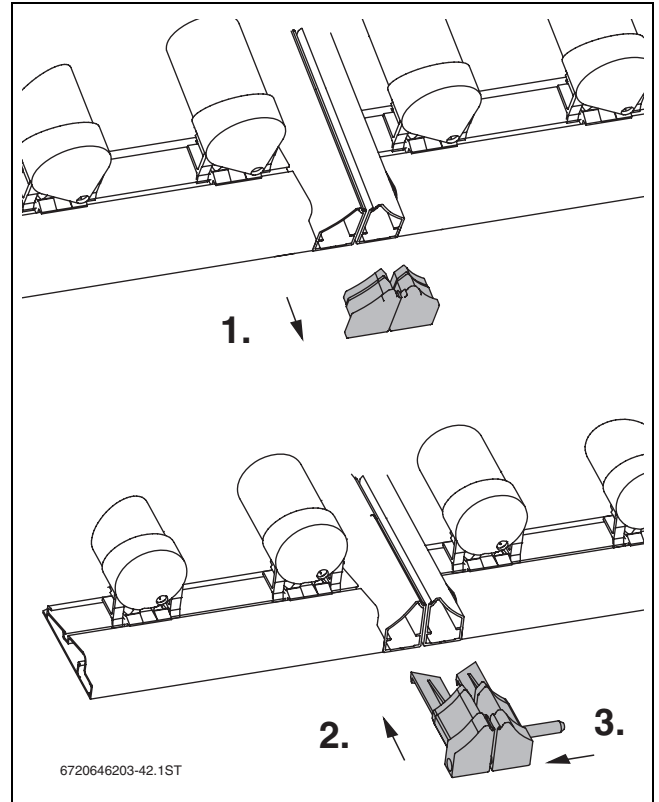



Fig. 33 Bottom of collector: exchanging the plugs

## 10 HYDRAULIC CONNECTIONS

For information regarding the routing of pipework between the components (collectors, solar pump station, solar cylinder), see the "Solar pump station" installation instructions.

 **NOTE:** Roof/wall leaks through incorrect pipework outlets.

- ▶ If required, ask a specialist contractor to route the pipework into the building.

 Route the sensor lead with the flow pipe to the collector.

### CONNECTING PIPEWORK

The hydraulic connection with the pipework is made via angled compression fittings.

 **NOTE:** Collector damage through over tightening.

- ▶ Counterhold with SW19 spanner at the spanner faces of the angled fittings [2].
- ▶ Tighten the nuts at the collector connection with a SW24 spanner.

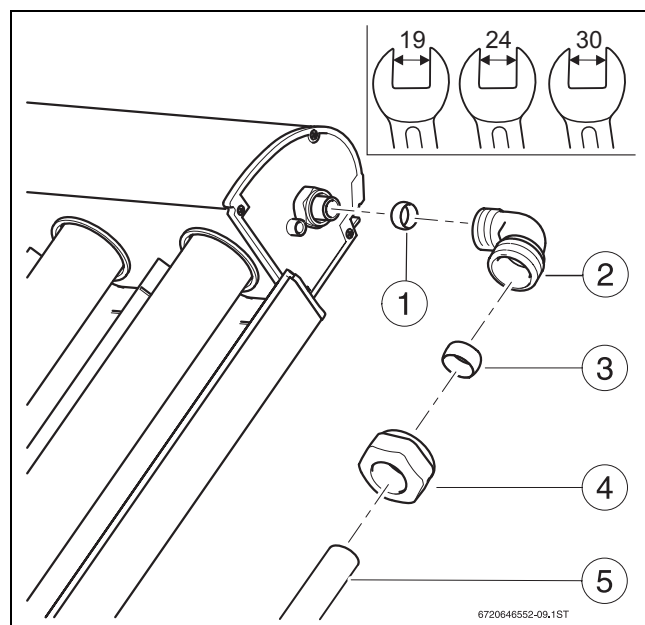



Fig. 34 Connection pipe and collector fittings

- 1 Olive 18 mm (pre-fitted)
- 2 Angled fitting with spanner face SW19
- 3 18 mm olive
- 4 Union nut
- 5 Pipework, on site

 **CAUTION:** Risk of scalding through loose fittings.

- ▶ Check all fittings for correct tightness.

- ▶ Connect the pipe [5] to the angled fitting (use SW30 spanner, → Fig. 34). Counterhold with SW19 spanner at the angled fittings.

**INSTALLING THE SHUT-OFF VALVE (ACCESSORY)**

For collector arrays consisting of several rows of collectors connected in parallel, each collector array must be purged and vented separately. In order to do so, each row of collectors requires a shut-off valve in the flow.

**NOTE:** Collector damage from overpressure. The piping between the collector and the expansion vessel (EV) or safety valve must not be shut off.

- ▶ Install the shut-off valve with the olive fittings (2 fittings supplied) in the flow of the collector.

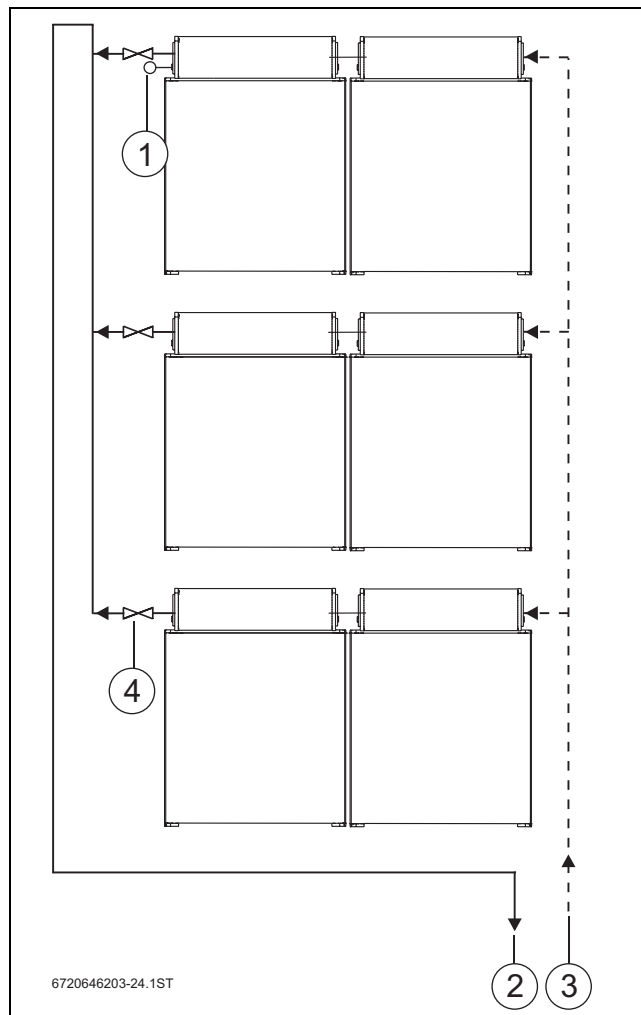

Fig. 35 Three-row connection (with shut-off ball valve), here: flow on the left

- 1 Collector sensor
- 2 Flow pipe (to the cylinder)
- 3 Return pipe (from the cylinder)
- 4 Shut-off valve



To purge and vent a row of collectors, always open the shut-off valve for this row only. The other shut-off valves remain closed. Open all shut-off valves after purging and venting. Observe the additional notes on pressure filling in the instructions for the solar pump station as well as the filling station.

# 11 FINAL ACTIVITIES

## 11.1 CHECKING THE INSTALLATION



Once the following checks have been performed, you can carry out the final insulation activities.

Checks		
1.	Are all connection fittings tightened?	<input type="radio"/>
2.	Are all threaded fittings on rails, mounting brackets and retaining clips tightened?	<input type="radio"/>
3.	Is the collector sensor inserted up to the end-stop?	<input type="radio"/>

Tab. 17

## 11.2 PRESSURE FILLING, PURGING, VENTING

The solar thermal system must be filled by means of pressure filling, purged and vented. Observe the notes on pressure filling in the installation instructions for the solar pump station as well as the filling station.



**NOTE:** Collector damage from frost.  
 ▶ Carry out pressure filling using LS heat transfer medium for purging and filling the system.  
 Do not use water because the collectors cannot be drained!

## 11.3 ADJUSTING THE PRE-CHARGE PRESSURE OF THE EXPANSION VESSEL

Before filling the solar thermal system, check the pre-charge pressure of the expansion vessel.



The expansion vessel pre-charge pressure is calculated from the static system head plus 1.7 bar (static system head = difference in head between the expansion vessel connection and the top edge of the collector; 1 metre difference in head corresponds to 0.1 bar).

**Example:** 10 m difference in head corresponds to 1.0 bar plus 1.7 bar = 2.7 bar.

- ▶ Correct the pre-charge pressure of the expansion vessel, if necessary.

## 11.4 DETERMINING AND SETTING THE OPERATING PRESSURE

After carrying out pressure filling and purging as well as a pressure test (→ solar pump station instructions), you must determine and set the required operating pressure. For information on how to proceed, please refer to the instructions for the solar pump station.



The operating pressure is calculated from the static system head plus 2.0 bar (static system head = difference in head between the expansion vessel connection and the top edge of the collector; 1 metre difference in head corresponds to 0.1 bar).

**Example:** 10 m difference in head corresponds to 1.0 bar plus 2.0 bar = 3.0 bar.

## 11.5 ADJUSTING THE FLOW RATE



Observe the information in the installation and maintenance instructions for the solar pump station (chapter entitled "Adjusting the flow rate").

Number of collectors	Flow rate in l/min (for flow temperature of 20 °C)	
	Solar-Lux 6 (l/min)	Solar-Lux 12 (l/min)
1	--	2.0
2	2.0	4.0
3	3.0	5.5
4	4.0	--
5	4.5	--
6	5.5	--

Tab. 18 Flow rate to be adjusted for non-variable speed solar controllers subject to the number and type of collectors

## 11.6 INSULATING PIPING

### ON-SITE INSULATION OF PIPING

- ▶ Use insulation resistant to UV light and high temperatures for outdoor piping.
- ▶ Use insulation resistant to high temperatures for indoor piping.
- ▶ Make the insulation bird-proof.

## 12 REPLACING INDIVIDUAL TUBES

You can tell when a tube is broken because the silver deposits in the bottom part of the tube will have turned white.

**WARNING:** Risk of injury from broken glass.

- ▶ When handling the collectors, always wear protective gloves and goggles.

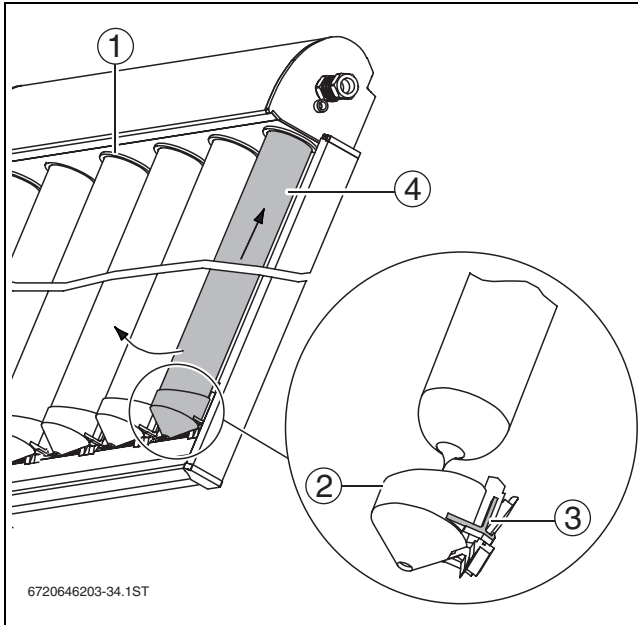

Fig. 36

- 1 Silicone ring
- 2 Tube holder
- 3 Release lever
- 4 Tube

### REMOVING A MECHANICALLY DESTROYED TUBE

- ▶ Carefully remove broken glass without damaging the surface of the CPC mirror.
- ▶ Remove tube holder [2] at the bottom.

### REMOVING A TUBE IS NOT MECHANICALLY DESTROYED

- ▶ To remove the tube holder [2] at the bottom,
  - push up the tube 5 mm into the manifold and
  - push down the two release levers [3] on the right and left using your thumb and pointer finger.
- ▶ Lift the tube holder toward the manifold to release it.
- ▶ Lift the tube somewhat and turn it about the longitudinal axis to pull it straight down and out.

### INSTALLING THE TUBE

Install the new tube [4] the same way that you removed the old tube.

Make sure that the silicone ring [1] fits tightly in the manifold.

- ▶ Apply soapsuds or lubricant paste to the top of the tube.
- ▶ Turning the tube slightly, push it through the silicone ring into the manifold.
- ▶ Place the tube holder [2] on the end of the tube, push it in between the notches in the aluminium profile and engage it in the groove.
- ▶ Pull down the tube into the tube holder to the end-stop.

## 13 ENVIRONMENTAL PROTECTION / DISPOSAL

Environmental protection is our principal policy.

Quality of performance, efficiency and environmental protection are equally important objectives for us. All legislation and regulations pertaining to the environment are strictly observed. To protect the environment, we use the best possible technology and materials.

### **DISPOSAL**

At the end of their service life, materials should be recycled in the most environmentally compatible method of recycling.

# 14 MAINTENANCE/INSPECTION

The collector array must be checked at regular intervals (inspection). Defects/faults must be remedied without delay (maintenance). We recommend conducting the first maintenance/inspection after about 500 hours run, and then at intervals of 1-2 years.

Use the table as a copy template so that you will have documentation available even after the third maintenance.



**DANGER:** Risk to life through falls and falling parts!

- ▶ For all work on the roof, take appropriate measures to prevent accidents.
- ▶ Secure the roof against falls.
- ▶ Always wear your own protective clothing or safety equipment.

▶ Fill out the report and tick off the tasks performed.

Owner:	Site location:
--------	----------------

Maintenance and inspection tasks	Page	Maintenance/inspection			
<b>Date</b>					
1.	Visual inspection of the collectors carried out (correct seating of glass tubes, visual impression)?		<input type="radio"/>	<input type="radio"/>	<input type="radio"/>
2.	Collector sensor correctly positioned and inserted into the sensor well as far as it will go?	20	<input type="radio"/>	<input type="radio"/>	<input type="radio"/>
3.	Visual inspection of the mounting structure carried out?		<input type="radio"/>	<input type="radio"/>	<input type="radio"/>
4.	Visual inspection for leaks carried out at points where the mounting structure meets the roofing?		<input type="radio"/>	<input type="radio"/>	<input type="radio"/>
5.	Visual inspection of pipe insulation carried out?		<input type="radio"/>	<input type="radio"/>	<input type="radio"/>
<b>Notes</b>					
	The collector array was maintained in accordance with these installation instructions.		<input type="radio"/>	<input type="radio"/>	<input type="radio"/>
			Date, stamp, signature	Date, stamp, signature	Date, stamp, signature

Tab. 19

Worcester, Bosch Group  
Cotswold Way, Warndon, Worcester WR4 9SW.  
Tel. 0844 892 9900  
Worcester, Bosch Group is a brand name of Bosch Thermotechnology Ltd.

[worcester-bosch.co.uk](http://worcester-bosch.co.uk)

6 720 647 041

**WORCESTER, BOSCH GROUP:**

TECHNICAL SUPPORT: 0844 892 3366

APPOINTMENTS: 0844 892 3000

SPARES: 01905 752571

LITERATURE: 0844 892 9800

TRAINING: 01905 752526

SALES: 01905 752640

