

# TECHNICAL BULLETIN

## PRODUCT: Greenstar appliances which utilise the WB6 Heat-Cell.

### Re-Assembly of the burner clamp plate.

Manuals which include instructions relating to the re-assembly of the WB6 burner clamping plate have been revised to give more clear guidance on reassembly of the clamp plate assembly.

This guidance must be followed when reassembling the clamp plate assembly.

#### 6.8.10 RE-ASSEMBLY OF THE BURNER CLAMPING PLATE

**NOTICE:** Heat exchanger seal

- ▶ If the joint between the Air/Gas manifold and heat exchanger is disturbed the sealing gasket must be replaced.
- ▶ After re-assembly the combustion must be checked As per directions given in the installation manual

- ▶ Ensure that the new gasket is fitted, with the electrode assembly and gasket heat shield

**CAUTION:** Clamping plate

- ▶ Ensure that the clamping plate is firmly tightened down on top of the heat exchanger.

- ▶ Locate the edge of the clamping plate [7] under the bracket [4] and fit the retaining plate [1] hand tight
- ▶ Ensure that the retaining plate [1] is in the position shown in figure 103
- ▶ At this point the Air/Gas Manifold/Fan assembly [8] should be fitted, engage the lugs in the slots in the clamping plate and rotate clockwise to the stop position.
- ▶ Rotate the retaining plate assembly [1] in the slot on the clamping plate [2], this will prevent the Air/Gas manifold [8] rotating back
- ▶ Initially there will be a gap between the clamping plate and the top of the heat exchanger, refer to figure 103

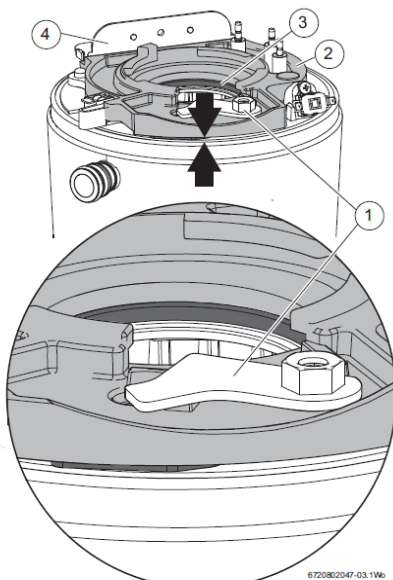

Fig. 103 Initial location of the clamping plate

- [1] Retaining plate assembly
- [2] Clamping plate
- [3] Gasket
- [4] Bracket
- [5] Underside view of the clamping plate
- [6] Mating surface
- [7] Location edge
- [8] Air/Gas manifold assembly

- ▶ Tighten the nut on the retaining plate assembly [1] until the underside face of the clamping plate mates with the top of the heat exchanger as indicated by the two arrows in figure 105
- ▶ Refer to figure 104 for detail of the clamping and mating surface [6]
- ▶ It is important to clamp the plate down firmly, without over tightening, to the heat exchanger to ensure a gas tight seal

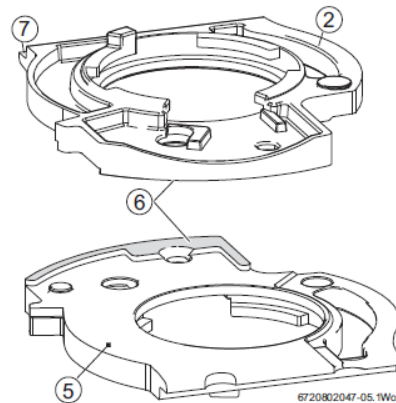

Fig. 104 Clamping plate detail

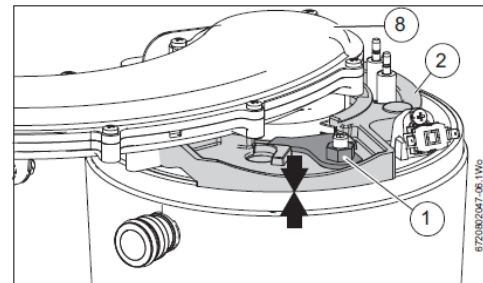

Fig. 105 Clamping plate secured

Particular attention must be paid to figure 105 and the instruction relating to this diagram. You must ensure that the mating surfaces come completely together.

Allan Downes.