

INSTALLATION AND SERVICING INSTRUCTIONS

SOLAR PUMP STATIONS

AGS 5/5E, AGS 10/10E

FOR SEALED SOLAR HEATING SYSTEMS AND INDIRECT FED DOMESTIC HOT WATER

7747006489.00-1 SD

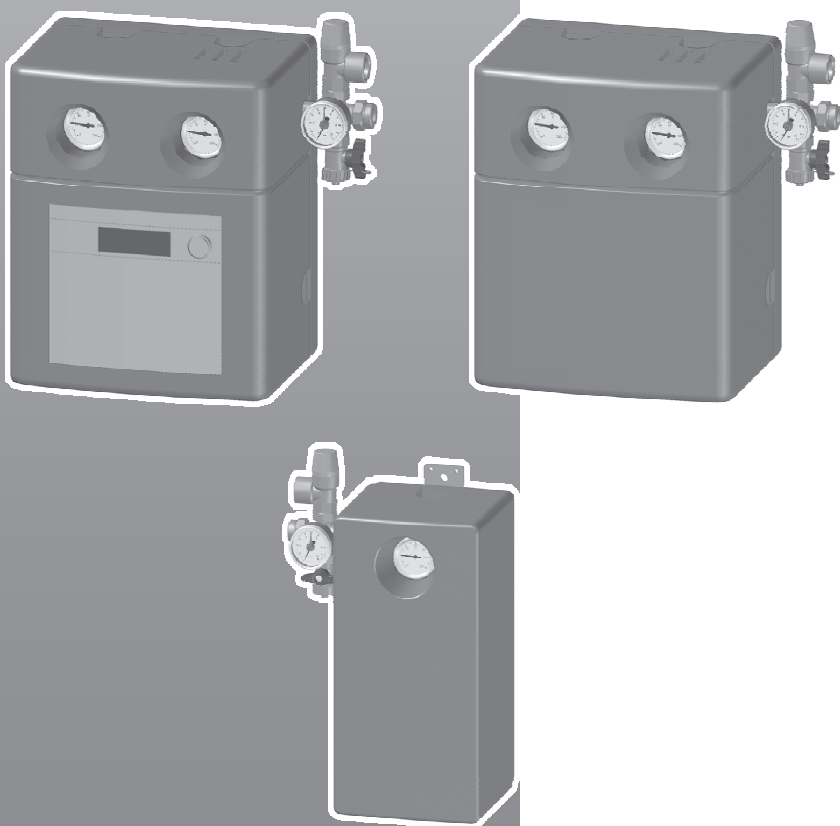

CONTENTS

1	Safety instructions and explanation of symbols	3	6	Commissioning	14
1.1	General safety instructions	3	6.1	Use of heat transfer fluid	14
1.2	Symbols	3	6.2	Purging and filling with a hand pump (air vent on roof)	14
			6.2.1	Purging the pipes	14
			6.2.2	Carrying out pressure test with water	15
2	Information about the product	4	6.2.3	Replacing water with heat transfer fluid	16
2.1	EU Declaration of Conformity	4	6.2.4	Verifying that the solar heating system is free of air	16
2.2	Correct use	4	6.2.5	Determining the operating pressure	16
2.3	Included in delivery	4	6.2.6	Determining the frost protection temperature	17
2.4	Product description	4	6.2.7	Correcting frost protection	17
2.5	Specifications and variants	5	6.3	Adjusting the flow rate	17
2.6	Example applications	6			
3	Regulations	7	7	Commissioning, inspection and maintenance report	19
4	Installing pipework	8	8	Fault finding	21
4.1	General information regarding pipework	8			
4.2	Installation of solar pipework	9			
5	Installing the solar pump station	10			
5.1	Layout of the installation space	10			
5.2	Mounting the solar pump station	10			
5.3	Electrical connection	10			
5.4	Installing the safety assembly	11			
5.5	Connecting the expansion vessel and pre-cooling vessel	11			
5.5.1	Installing the pre-cooling vessel (available as accessory)	11			
5.5.2	Installing the expansion vessel (available as an accessory)	12			
5.5.3	Adjusting the inlet pressure of the expansion vessel	12			
5.6	Connecting pipes and blow-off line to the solar pump station	12			
5.7	Installing the temperature sensors	13			
5.7.1	Collector temperature sensor	13			
5.7.2	Storage tank temperature sensor	13			

1 SAFETY INSTRUCTIONS AND EXPLANATION OF SYMBOLS

1.1 EXPLANATION OF SYMBOLS

WARNINGS

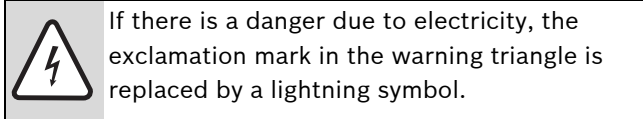
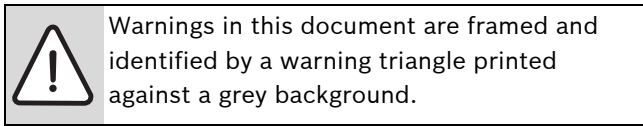

Keywords at the start of a warning indicate the type and seriousness of the ensuing risk if measures to prevent the risk are not taken.

- **NOTICE** indicates that material losses may occur.
- **CAUTION** indicates that minor to medium injury may occur.
- **WARNING** indicates that severe injury may occur.
- **DANGER** indicates a risk to life.

IMPORTANT INFORMATION

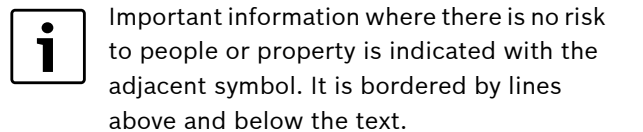

ADDITIONAL SYMBOLS

Symbol	Meaning
▶	Action step
→	Cross-reference to other parts of this document or to other documents
•	List/list entry
–	List/list entry (second level)

Tab. 1

1.2 GENERAL SAFETY INSTRUCTIONS

ABOUT THIS MANUAL

This manual contains important information for the safe and correct installation and maintenance of the solar pump station.

This manual is intended for qualified technicians.

The illustrations in this manual show the 2-line solar pump station with external controller.

- ▶ Give the manual to the customer, and explain how the device works and how to operate it.

PLEASE OBSERVE THESE INSTRUCTIONS

- ▶ Please read these instructions carefully.
- ▶ To prevent injury and property damage, always follow the safety instructions.
- ▶ Any tasks that require the solar pump station to be opened must be carried out by qualified electricians.
- ▶ The electrical supply must be connected by a qualified electrician.
- ▶ Before opening the solar pump station, it must be isolated from the power supply.
- ▶ Install a blending valve to limit the temperature at the tap to a maximum of 60°C.
- ▶ Do not make modifications to the device.
- ▶ Use only materials which can withstand possible temperatures up to 150°C.
- ▶ Purge and fill the solar heating system only when the sun is not shining on the collectors and (if purging with water) no frost is expected.

2 INFORMATION ABOUT THE PRODUCT



Benchmark places responsibilities on both manufacturers and installers. The purpose is to ensure that customers are provided with the correct equipment for their needs, that it is installed, commissioned and serviced in accordance with the manufacturer's instructions by competent persons and that it meets the requirements of the appropriate Building Regulations. The Benchmark Checklist can be used to demonstrate compliance with Building Regulations and should be provided to the customer for future reference.

Installers are required to carry out installation, commissioning and servicing work in accordance with the Benchmark Code of Practice which is available from the Heating and Hotwater Industry Council who manage and promote the scheme. Visit www.centralheating.co.uk for more information

2.1 EU DECLARATION OF CONFORMITY

The design and operation of this product conform to the applicable European directives and supplementary national requirements. The conformity has been confirmed.

2.2 CORRECT USE

AGS solar pump stations must only be used for the operation of solar heating systems in conjunction with suitable controllers from the same manufacturer.

AGS solar pump stations are solely designed for operating solar heating systems filled with propylene glycol/water mixtures (Tyfocor L or Tyfocor LS). Do not use any other heat transfer medium.

2.3 INCLUDED IN DELIVERY

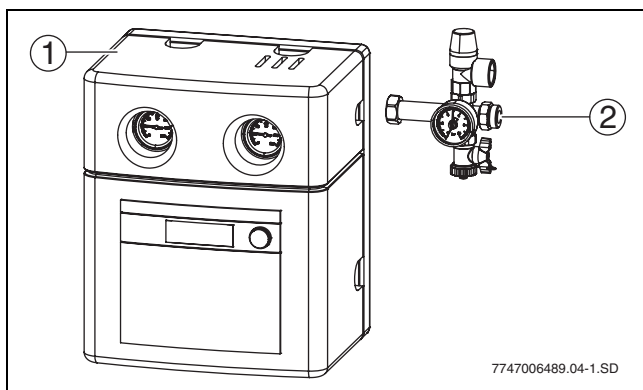

Fig. 1 Package contents - Solar pump station with controller

- 1 Solar pump station (1- or 2-line solar pump station with/ without controller)
- 2 Safety assembly (safety valve, pressure gauge, fill & drain valve)

And

Mounting materials (not shown)

2.4 PRODUCT DESCRIPTION

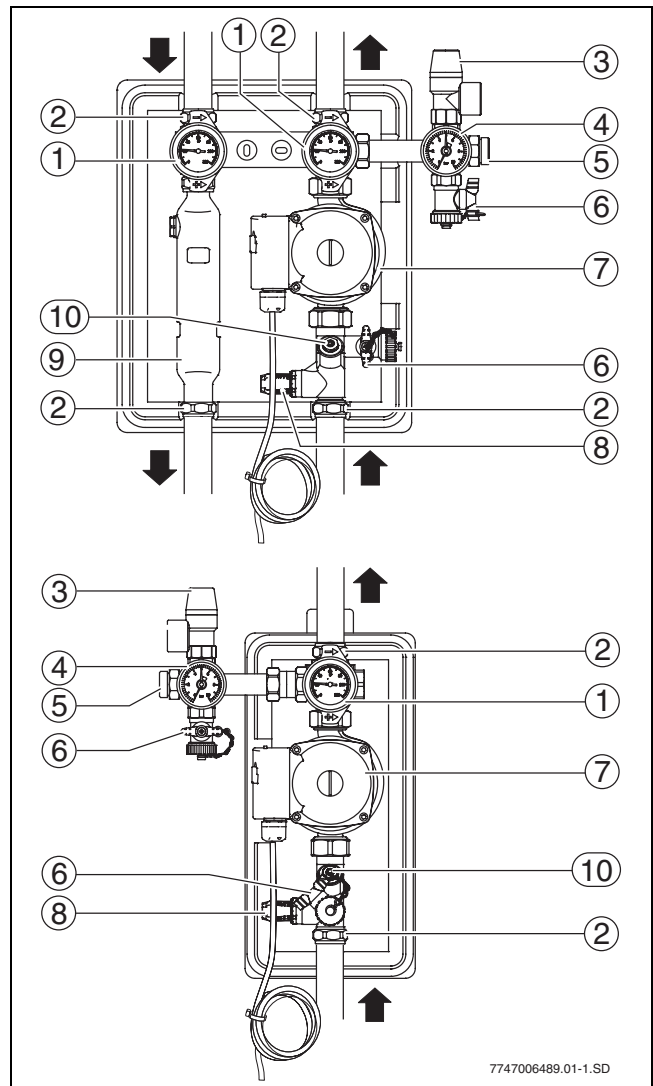

Fig. 2 Solar pump stations without front insulation casing and without built-in controller

- 1 Ball valve with thermometer (red=flow¹⁾, blue=return) and integrated gravity brake:
 - 0° = gravity brake ready for operation,
 - 45° = gravity brake manually open
- 2 Compression fitting
- 3 Safety valve
- 4 Pressure gauge
- 5 Connection to diaphragm expansion vessel
- 6 Fill & drain valve
- 7 Solar pump
- 8 Flow rate indicator
- 9 Air eliminator¹⁾
- 10 Control/shut-off valve

1) Not for 1-line solar pump station

2.5 SPECIFICATIONS AND VARIANTS

		AGS 5	AGS 5E
Maximum possible temperature	°C	Flow: 130 / return: 110 (pump)	
Safety valve response pressure	bar	6	6
Safety valve	–	DN 15, ¾ " connection	DN 15, ¾ " connection
Mains supply	–	230V AC, 50 - 60 Hz	230V AC, 50 - 60 Hz
Maximum current consumption per pump	A	0.25	0.25
Dimensions (HxWxD)	mm	355x290x235	355x185x180
Flow and return connections (compression fittings)	mm	15	15
Number of collectors	–	1 - 5	1 - 5

Tab. 2 Specifications for AGS 5 and AGS 5E

		AGS 10	AGS 10E
Maximum possible temperature	°C	Flow: 130 / return: 110 (pump)	
Safety valve response pressure	bar	6	6
Safety valve	–	DN 15, ¾ " connection	DN 15, ¾ " connection
Mains supply	–	230V AC, 50 - 60 Hz	230V AC, 50 - 60 Hz
Maximum current consumption per pump	A	0.54	0.54
Dimensions (HxWxD)	mm	355x290x235	355x185x180
Flow and return connections (compression fittings)	mm	22	22
Number of collectors	–	6 - 10	6 - 10

Tab. 3 Specifications for AGS 10 and AGS 10E

2.6 EXAMPLE APPLICATIONS

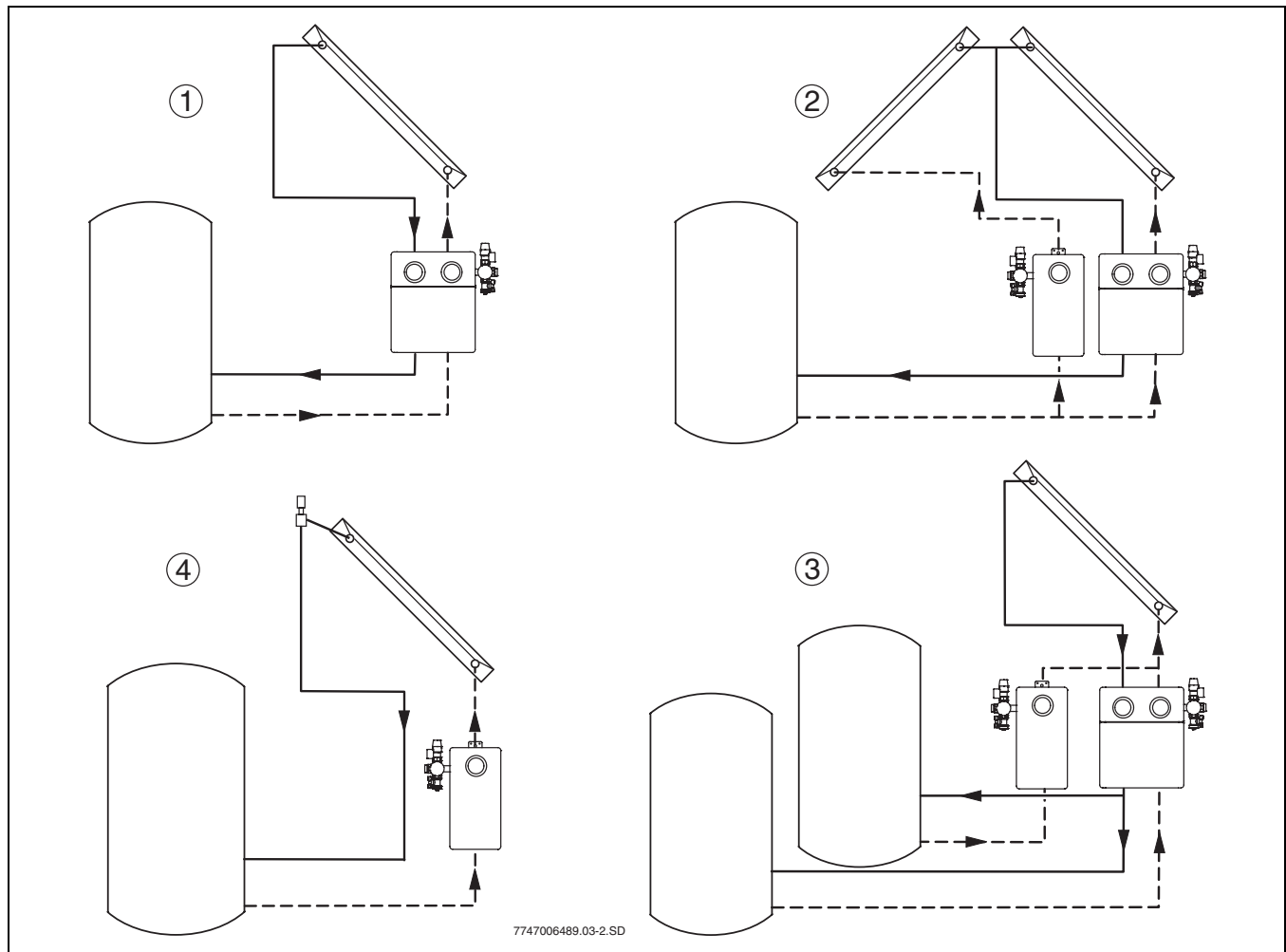

Fig. 3 Different hydraulic applications

- 1 Standard system with 2-line solar pump station
- 2 Two collector arrays (east/west) with 1-line and 2-line solar pump stations
- 3 Dual-tank system with 1-line and 2-line solar pump stations
- 4 Standard system with 1-line solar pump station and air vent on roof

3 REGULATIONS

Observe all standards and guidelines applicable to the installation and operation of the system in your country and region.

TECHNICAL REGULATIONS APPLICABLE IN THE U.K. FOR THE INSTALLATION OF THERMAL SOLAR HEATING SYSTEMS

- Electrical connection:
 - Current IEE wiring regulations
- Connection of thermal solar systems:
 - EN 12976: Thermal solar systems and components (factory made systems)
 - ENV 12977: Thermal solar systems and components (custom built systems)
 - BS5918: Latest version: Solar heating systems for domestic hot water.
- Installation and fittings of hot water heaters:
 - BS5546:2006 Specification for installation of hot water supplies for domestic purposes, using gas-fired appliances of rated input not exceeding 70kW.
 - BS6700:2006 Specifications for design, installation testing and maintenance of services supplying water for domestic use within buildings and their curtilages.

4 INSTALLING PIPEWORK

4.1 GENERAL INFORMATION REGARDING PIPEWORK

CAUTION: System damage from plastic pipes (e.g. PE pipes)

- ▶ Use only materials which can withstand the temperatures up to 150 °C which occur in solar heating systems.

The collectors, the solar pump station and the solar storage tank are interconnected with copper pipes.

- ▶ To prevent air locks: route the pipes from the tank to the collector on a rising incline.

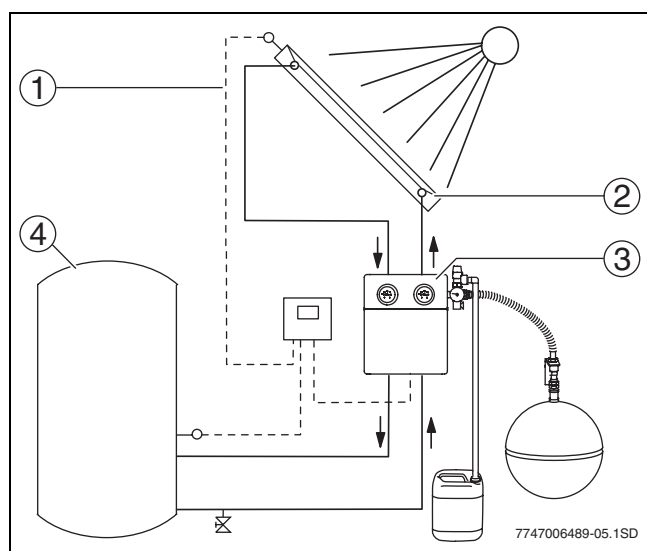

Fig. 4 The piping of the solar heating system

- 1 Wire to the collector temperature sensor
- 2 Collectors
- 3 Solar pump station
- 4 Solar storage tank

CONNECTING THE PIPES

CAUTION: System damage from heat buildup when brazing

- ▶ Do not carry out brazing close to evacuated tube collectors.

- ▶ Copper pipes for solar heating systems should always be brazed (i.e. no low-temperature soldering).

Compression fittings or pressfittings can be used instead of brazing if they are glycol- and heat-resistant (150 °C).

- i** We recommend carrying out a pipe network analysis to determine pipe requirements. Basic design estimates can be made using Tab. 4.
- ▶ If there are many additional points of resistance (bends, valves etc.), you may need to select a pipe with a larger diameter.

Straight pipe length	Number of collectors	
	Up to 5	Up to 10
Up to 6 m	Double pipe 15 Ø 15 mm (DN12)	Ø 22 mm (DN15)
Up to 10 m	Double pipe 15 Ø 15 mm (DN12)	Ø 22 mm (DN20)
Up to 15 m	Double pipe 15 Ø 15 mm (DN12)	Ø 22 mm (DN20)
Up to 20 m	Ø 22 mm (DN15)	Ø 22 mm (DN20)
Up to 25 m	Ø 22 mm (DN15)	Ø 28 mm (DN25)

Tab. 4 Pipe sizing

- i** If threaded pipe connections are caulked with hemp:
- ▶ Use a thread sealing paste resistant to temperatures up to 150 °C (e.g. NeoFermit universal).

4.2 INSTALLATION OF SOLAR PIPEWORK

EARTHING PIPES

Work must be carried out by an authorised electrician.

- ▶ One earthing clamp must be fitted to both the flow pipe and the return pipe (at any position).
- ▶ Connect the earthing clamps to the building's equipotential bonding strip by means of a standard PVC-sheathed bonding cable (NYM type, at least 6 mm²).

INSTALLING SOLAR PIPEWORK WITH AN AUTOMATIC AIR VENT ON THE ROOF (AVAILABLE AS ACCESSORY)

- ▶ Connect pipes to the air vent on a rising incline. For every downwards change of direction an additional air vent unit is required (heat-resistant to 150 °C).

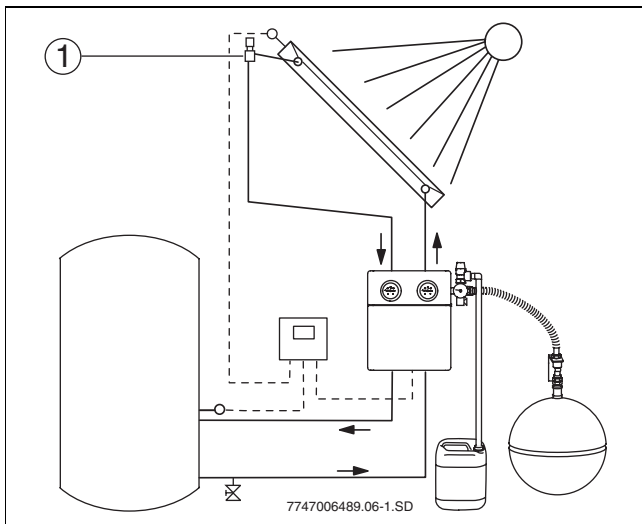

Fig. 5 Position of the automatic air vent valve

- 1 Automatic air vent

INSULATING PIPES

- ▶ Insulate outdoor pipework with material which is class O rated, which is resistant to UV and to high temperatures (150 °C).
- ▶ Insulate indoor piping with material which is resistant to high temperatures (150 °C).

5 INSTALLING THE SOLAR PUMP STATION

5.1 LAYOUT OF THE INSTALLATION SPACE

CAUTION: Damage to the solar heating station from pump buildup

- ▶ Make sure that the ventilation slots, at the top and bottom of the thermal-protective casing, are open.

- ▶ To make it easier to connect the temperature sensors: install the solar pump station (2) as close as possible to the solar storage tank (1).
- ▶ Allow enough room for an expansion vessel (3) and storage vessel (4).

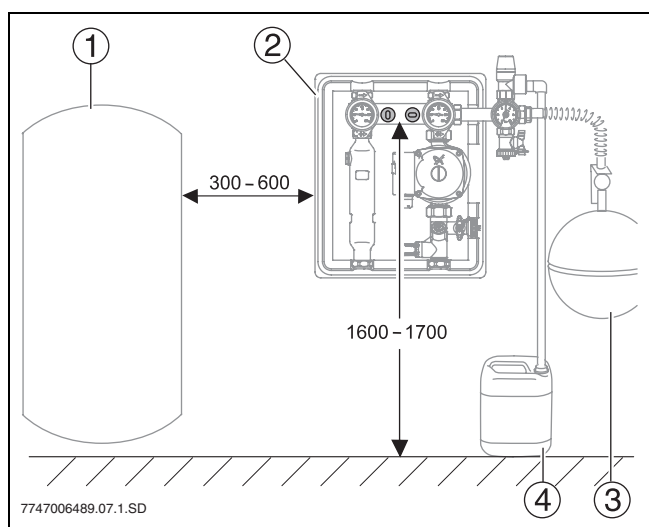

Fig. 6 Recommended positioning (measurements in mm)

- 1 Solar storage tank
- 2 Solar pump station
- 3 Expansion vessel
- 4 Storage vessel

5.2 MOUNTING THE SOLAR PUMP STATION

1-LINE SOLAR PUMP STATION

- ▶ Drill a hole (2) and mount the solar pump station using the wall plug and screw supplied.

2-LINE SOLAR PUMP STATION

- ▶ Drill holes (1) 60 mm apart and mount the solar pump station using the wall plugs and screws supplied.

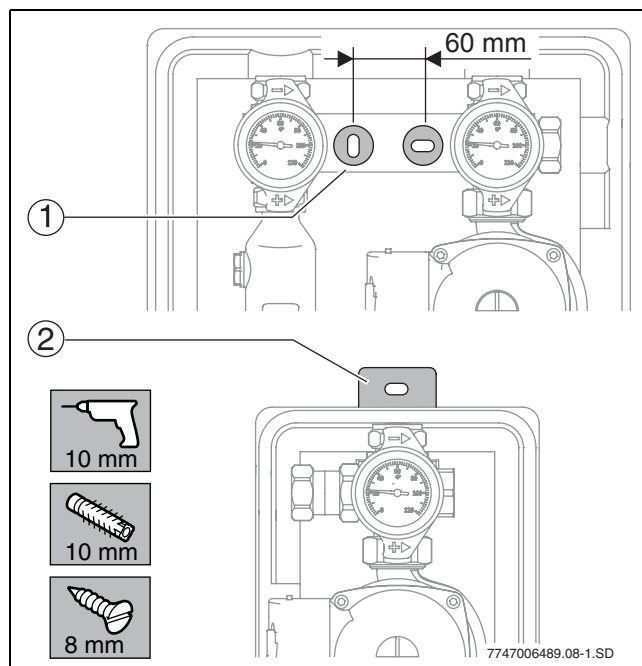

Fig. 7 Mounting the station

- 1 Mounting for 2-line solar pump station
- 2 Mounting for 1-line solar pump station

5.3 ELECTRICAL CONNECTION

Electrical connections must be carried out by properly authorised electricians and subject to locally applicable regulations.

CAUTION: Damage to pump

- ▶ Do not put the pump into operation until the pipework has been filled. Otherwise the pump can be damaged.

- ▶ Connect the cables for the pumps and temperature sensors to the controller as directed by the installation instructions for the controller.

5.4 INSTALLING THE SAFETY ASSEMBLY



For 1-line solar pump station:

- ▶ Install the safety assembly on the left.

For 2-line solar pump station:

- ▶ Install the safety assembly on the right.

- ▶ Install the safety assembly on the solar heating station together with the gasket supplied (1).

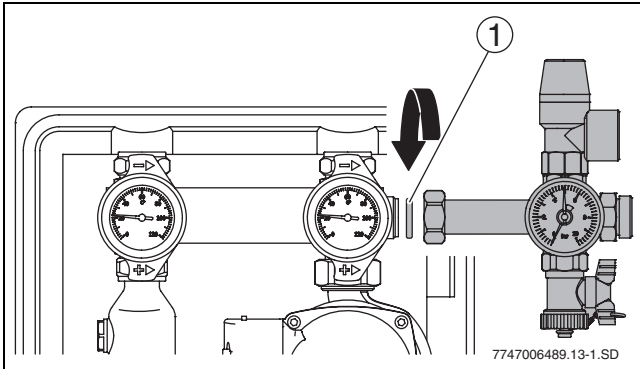

Fig. 8 Installing the safety assembly of 2-line solar pump station

- 1 Gasket (21x30x2)

5.5 CONNECTING THE EXPANSION VESSEL AND PRE-COOLING VESSEL



Do not insulate the pre-cooling vessel (if fitted) and the expansion vessel, nor the pipes connecting them to the safety assembly.

5.5.1 INSTALLING THE PRE-COOLING VESSEL (AVAILABLE AS ACCESSORY)

A pre-cooling vessel is required:

- If the system is to be used to assist the central heating system.
- If the system is purely for DHW heating: the solar fraction is more than 60 %.

The pre-cooling vessel protects the expansion vessel from excessively high temperatures.

	5 litres	12 litres
Height	270 mm	270 mm
Diameter	160 mm	270 mm
Connection	2 x R 3/4 "	2 x R 3/4 "
Maximum operating pressure	10 bar	10 bar

Tab. 5 Pre-cooling vessel specifications

CONNECTING THE PRE-COOLING VESSEL

If the pipeline to the expansion vessel needs to be laid on a rising incline, an additional air vent must be installed.

- ▶ To protect the safety valve from excessive temperatures: connect the pre-cooling and expansion vessels with a tee (3/4 " threaded outer with flange gasket) in the return line 20 to 30 cm above the solar heating station.
- ▶ Secure pipes to and from the pre-cooling vessel with pipe clamps (4). Mount the pre-cooling vessel vertically.
- ▶ Connect the expansion vessel (5) to the pre-cooling vessel by means of a copper pipe.
- ▶ Seal the connection on the safety valve with a 3/4 " cap (2) (to be provided by the customer).

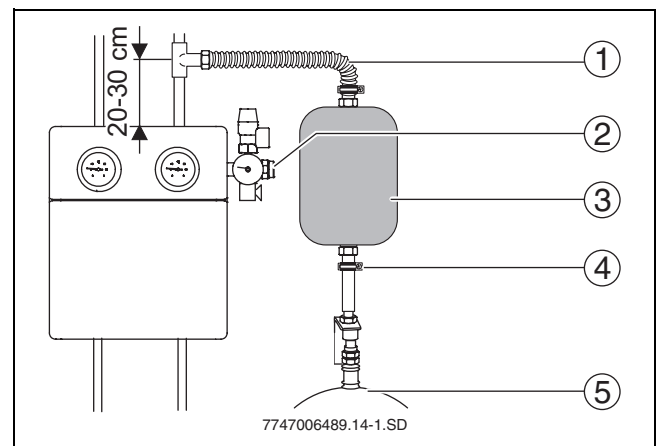

Fig. 9 Installing the pre-cooling vessel

- 1 Flexible stainless steel tube from the connection set for the expansion vessel (available as accessory)
- 2 Plug on the safety assembly connection (provided by customer)
- 3 Pre-cooling vessel
- 4 Pipe clamp (provided by customer)
- 5 Expansion vessel

**5.5.2 INSTALLING THE EXPANSION VESSEL
(AVAILABLE AS AN ACCESSORY)**

- ▶ Install the expansion vessel with the relevant mounting materials.
- ▶ Connect the expansion vessel (3) in the return line on the solar heating station's safety assembly.

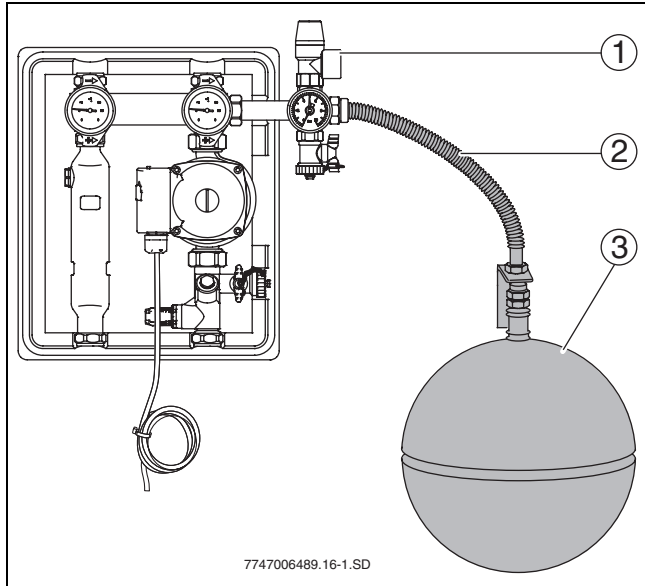

Fig. 10 Connecting the expansion vessel

- 1 Safety valve
- 2 Flexible stainless steel tube from connection set for the expansion vessel (available as an accessory)
- 3 Expansion vessel

5.5.3 ADJUSTING THE INLET PRESSURE OF THE EXPANSION VESSEL

i The inlet pressure of the expansion vessel is given by the static system height plus 0.5 bar (1 metre difference in height equals 0.1 bar).

- ▶ Set a minimum pressure of 1.5 bar.
-
- ▶ To make use of the maximum possible volume: set the inlet pressure when the vessel is not under stress (i.e. no fluid pressure).
 - ▶ If the calculated inlet pressure is higher or lower than the factory-set inlet pressure, correct the inlet pressure accordingly.

5.6 CONNECTING PIPES AND BLOW-OFF LINE TO THE SOLAR PUMP STATION

! **DANGER:** Possible injuries and system damage from incorrectly installed blow-off line

- ▶ Make sure the blow-off line has the same size as the cross-section of the safety valve (maximum length = 2 m and maximum of two bends).

- ▶ Cut the pipes to a length which will allow them to be pushed into the compression fitting (1) until they bottom out.
- ▶ Route the blow-off line (2) from the safety valve so that it can be seen to empty out into the storage vessel (4) and secure it in place with a pipe clamp (3).

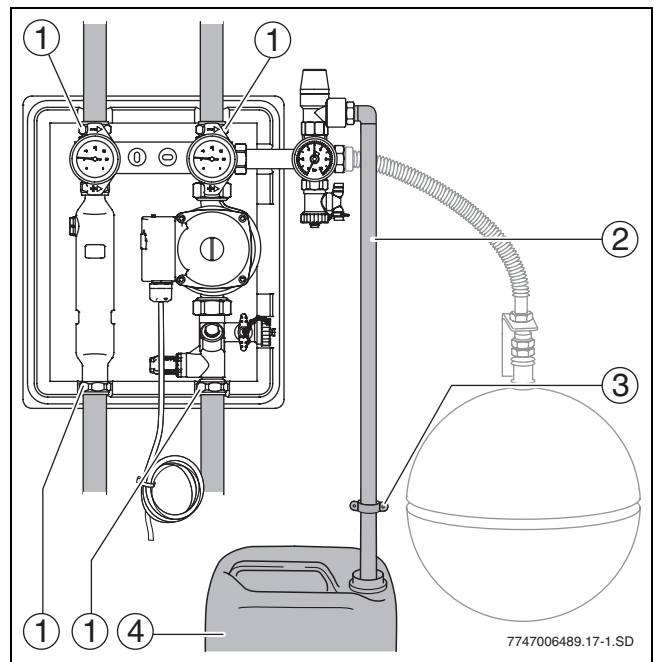

Fig. 11 Connection to solar pump station

- 1 Compression fitting
- 2 Blow-off line
- 3 Pipe clamp
- 4 Empty solar fluid container (storage vessel)

INSTALLING THE FILL AND DRAIN VALVE

- ▶ Install a fitting into the return pipe at the lowest point in the solar heating system for draining the solar heating system (tee with fill & drain valve, → Fig. 12, (4)).

5.7 INSTALLING THE TEMPERATURE SENSORS

Electrical connections must be carried out by authorised electricians.

The temperature sensors are protected against polarity reversal.

5.7.1 COLLECTOR TEMPERATURE SENSOR

If the collector sensor lead needs to be extended to reach the controller, a waterproof junction must be used at the connections where they are exposed to moisture.

- ▶ Extend the sensor lead with a two-core lead (3).
- ▶ If necessary, protect the connection points (2) at top and bottom with junction boxes.

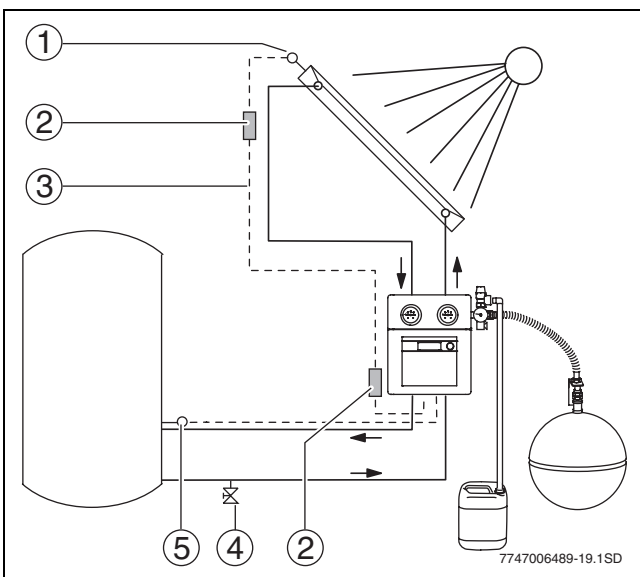

Fig. 12 Collector and storage tank temperature sensors to solar pump station with built-in controller

- 1 Collector temperature sensor
- 2 Connection point
- 3 Two-core lead (2 x 0.75 mm² up to a maximum length of 50 m)
- 4 Fill & drain valve for emptying (provided by customer)
- 5 Cylinder temperature sensor

5.7.2 STORAGE TANK TEMPERATURE SENSOR

For installation instructions and data, see the installation instruction manuals for the cylinder and the controller.

6 COMMISSIONING



At the time of commissioning, complete all relevant sections of the Benchmark Checklist located on the inside back pages of this document.

After servicing, complete the relevant Service Interval Record section of the Benchmark Checklist located on the inside back pages of this document.



CAUTION: System damage from frozen water or vaporisation in the solar heating circuit

- ▶ Purge and fill the solar heating system only when the sun is not shining on the collectors and (if purging with water) no frost is expected.



When filling with heat transfer fluid, take the additional volume of the pre-cooling vessel into account (if installed).

The pre-cooling vessel and the expansion vessel must be adequately drained.

6.1 USE OF HEAT TRANSFER FLUID



CAUTION: Risk of injury through contact with heat transfer fluid

- ▶ When handling heat transfer fluid, always wear protective gloves and goggles.
- ▶ If heat transfer fluid comes into contact with skin: wash off the heat transfer fluid with water and soap.
- ▶ If heat transfer fluid comes into contact with eyes: holding eyelids wide open, thoroughly wash eyes with running water.

The heat transfer fluid is pre-mixed and ready to use. It guarantees safe operation within the specified temperature range, protects the system from frost damage and minimises risk of vaporisation.

The fluid is biodegradable. A safety data sheet with further information regarding the heat transfer fluid can be requested from the manufacturer.

The collectors must only be operated with the following heat transfer fluids:

	Heat transfer fluid	Temperature range
Flat plate collectors	Tyfocor L 45/55	- 29 ... +170 °C
Evacuated tube collectors	Tyfocor LS	- 28 ... +170 °C

Tab. 6 Tyfocor type in relation to collector type

6.2 PURGING AND FILLING WITH A HAND PUMP (AIR VENT ON ROOF)

6.2.1 PURGING THE PIPES



If a pre-cooling vessel is installed:

- ▶ Disconnect the pre-cooling vessel from the solar heating circuit while purging so that the water remaining in the pre-cooling vessel does not get mixed with the heat transfer fluid.

- ▶ Use a hose (1) to connect the fill and drain valve on the safety assembly to the mains water supply.
- ▶ To drain the water away, connect a hose (2) to the fill & drain valve on the flow limiter.

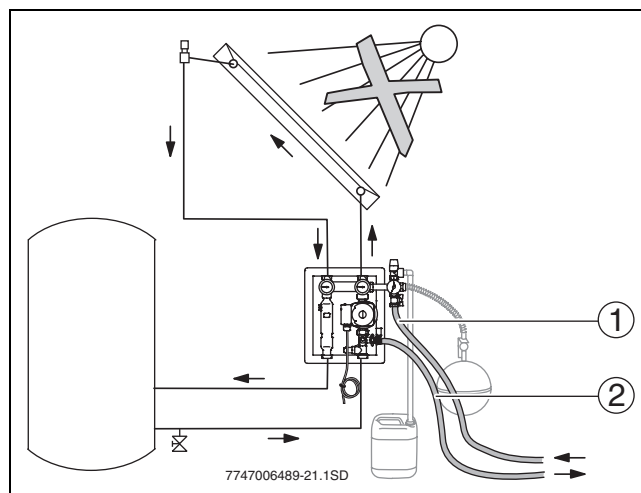

Fig. 13 Solar heating station with ball valves and gravity brakes in the thermometers

- 1 Hose for water supply
- 2 Hose for water drainage

- ▶ Open all shut-off fittings.
- ▶ Close the right-hand ball valve (2) on the solar heating station and the ball valve on the air vent (→ Fig. 15, (3)).
- ▶ Purge the pipework, making sure that the maximum operating pressure is not exceeded.
- ▶ Shut off the water supply.

- ▶ Close the fill and drain valves (3) in the solar heating station.

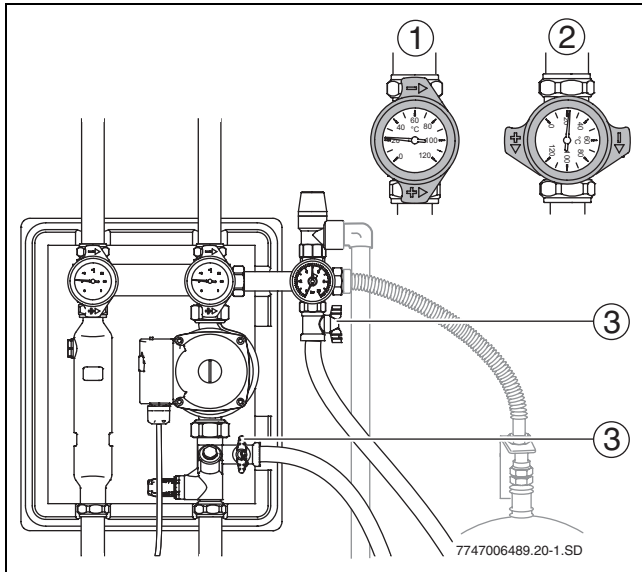

Fig. 14

- 1 Left-hand ball valve completely open (0°)
- 2 Right-hand ball valve closed (90°)
- 3 Fill & drain valves in the solar heating station

6.2.2 CARRYING OUT PRESSURE TEST WITH WATER

The solar heating system is vented by the opening of the plug screw (2) on the automatic air vent. To prevent moisture entering the air vent during operation, the weather protection cap (1) must always be over the plug screw.

- ▶ Open the ball valve (3).
- ▶ Unscrew the plug screw (2) one turn.

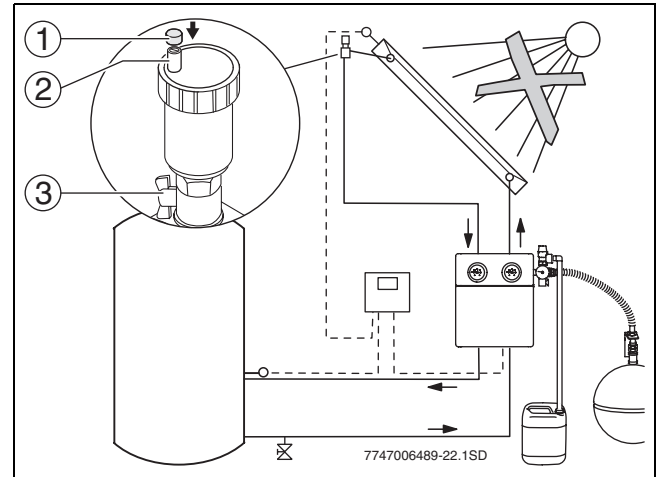

Fig. 15 Opening the air vent

- 1 Weather protection cap
- 2 Plug screw
- 3 Ball valve

- ▶ Set the ball valves (1) on the thermometers to 45° and open the flow limiter (2) and other shut-off fittings.

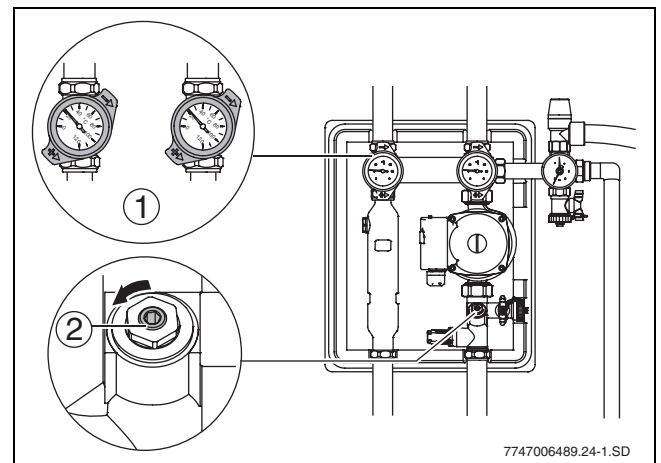

Fig. 16 Opened shut-off fittings

- 1 Ball valves and gravity brake open on the thermometers (45° position)
 - 2 Flow limiter open
- ▶ Carry out a pressure test to check compliance with the maximum permitted pressures of all components.
 - ▶ After the pressure test, drain the water and clean the automatic air vent.

6.2.3 REPLACING WATER WITH HEAT TRANSFER FLUID

i The pipes must be completely emptied of water, otherwise the heat transfer fluid can become diluted.

To add the heat transfer fluid, you can use electric pumps, hand pumps or power drill attachments capable of generating pressures of at least 2 bar.

- ▶ Using a pump, fill the solar heating system with fluid via one of the fill and drain valves (1) in the solar heating station.

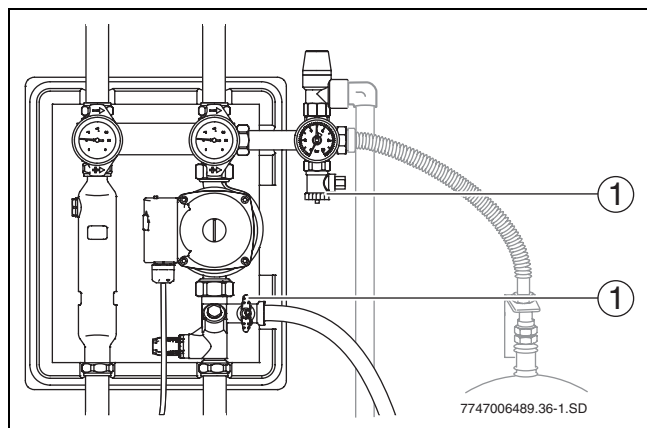

Fig. 17 Filling via fill & drain valve

1 Fill & drain valves

- ▶ Set the ball valves (→ Fig. 16, (1)) on the thermometers to 45° and open the flow limiter (→ Fig. 16, (2)) and other shut-off fittings.
- ▶ Fill the solar heating system slowly so that air bubbles do not form.
- ▶ Lastly, set the ball valves on the thermometers so that the gravity brakes are ready for operation (0° position).

6.2.4 VERIFYING THAT THE SOLAR HEATING SYSTEM IS FREE OF AIR

i If the black pointer on the pressure gauge (1) indicates pressure fluctuations when the solar pump is switched on and off, the solar heating system still contains air.

- ▶ Switch the solar pump(s) on and off manually.
- ▶ While switching the pump on and off, observe the black pointer on the pressure gauge (1) on the safety assembly.

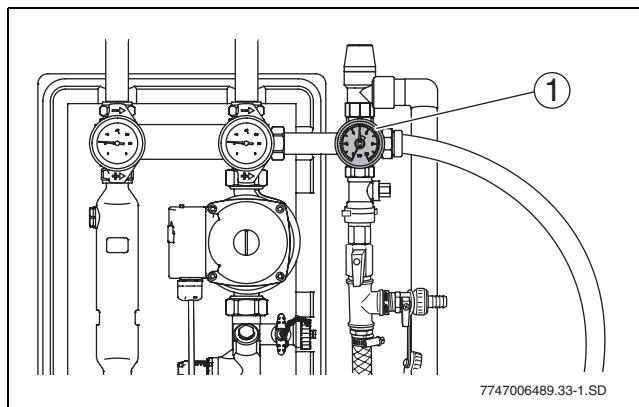

Fig. 18 Checking the pressure gauge display

1 Pressure gauge

6.2.5 DETERMINING THE OPERATING PRESSURE

When putting the system into operation, the operating pressure must be 0.8 bar above the static pressure (1 metre difference in height equals 0.1 bar).

The operating pressure must be at least 1.8 bar (when cold, 20 °C).

Example: 10 m static height equals 1.0 bar plus 0.8 bar = 1.8 bar operating pressure.

- ▶ If there is not enough pressure, pump in more heat transfer fluid.
- ▶ Once the venting procedure is complete, close the ball valve on the air vent.

When heat transfer fluid vaporises in the collectors, pressure compensation can only be carried out by the expansion vessel if the air vent is closed.

6.2.6 DETERMINING THE FROST PROTECTION TEMPERATURE

To determine the degree of frost protection, we recommend checking the frost protection of the heat transfer fluid when first putting the system into operation, by means of a frost protection gauge (a "Glykomat" or a refractometer). This check should be repeated at regular intervals (at least every two years).

The usual gauges used to test motor vehicle coolants are not suitable for this purpose. A suitable device can be ordered separately.

6.2.7 CORRECTING FROST PROTECTION



CAUTION: Frost damage

- ▶ Every two years, check whether the required frost protection level (to at least -25 °C) is being maintained.

If the minimum frost protection level is not being maintained, more heat transfer fluid concentrate must be added.

- ▶ Use Tab. 7 to determine the volume of the system, so that you can calculate the exact amount to be added (which is equal to the amount which first needs to be drained out).

System part	Volume
1 Solar-Lito Mini collector	0.62 l
1 Solar-Lito collector	0.80 l
1 Solar-Lifestyle collector portrait	0.94 l
1 Solar-Lifestyle collector landscape	1.35 l
1 Solar-Lux 6 collector	0.97 l
1 Solar-Lux 12 collector	2.12 l
1 one-line solar heating station	0.20 l
1 two-line solar heating station	0.50 l
1 m Cu pipe Ø 15 mm	0.13 l
1 m Cu pipe Ø 22 mm	0.31 l
1 m Cu pipe Ø 28 mm	0.53 l
1 m Cu pipe Ø 35 mm	0.86 l
1 m Cu pipe Ø 42 mm	1.26 l
1 m steel pipe R ¾	0.37 l
1 m steel pipe R 1	0.58 l
1 m steel pipe R 1¼	1.01 l
1 m steel pipe R 1½	1.37 l

Tab. 7 Volume of the separate system parts

- ▶ Use the following formula to determine the amount of concentrate to be added (V_{replace}) in the case of a pre-mixed 45/55 heat transfer fluid mixture:

$$V_{\text{replace}} = V_{\text{total}} \times \frac{45 - c_{\text{concentration}}}{100 - c_{\text{concentration}}}$$

Fig. 19 Formula for calculating the amount of fluid to be replaced for a heat transfer fluid with 45 % glycol

Example using Tyfocor L with 45 % glycol:

- System volume (V_{total}): 22 l
- Frost protection (recorded value): -14 °C
- Equals concentration (→ Tab. 7): 29 % (C = 30)
- Result: $V_{\text{replace}} = 4.7$ litres
- ▶ Drain the calculated amount to be added (V_{replace}) and add concentrate.

6.3 ADJUSTING THE FLOW RATE

The flow rate is set when the system is cold (30 - 40 °C).

- When the solar pump is speed-controlled, the controller determines the flow rate based on operating requirements.
- ▶ Set ball valves (1) to 0° (gravity brakes ready for operation).
- ▶ Using a size 4 Allen key, open the flow limiter (2) completely.
- ▶ Select the operating mode "Manual mode ON" on the controller (→ instruction manual for the controller).

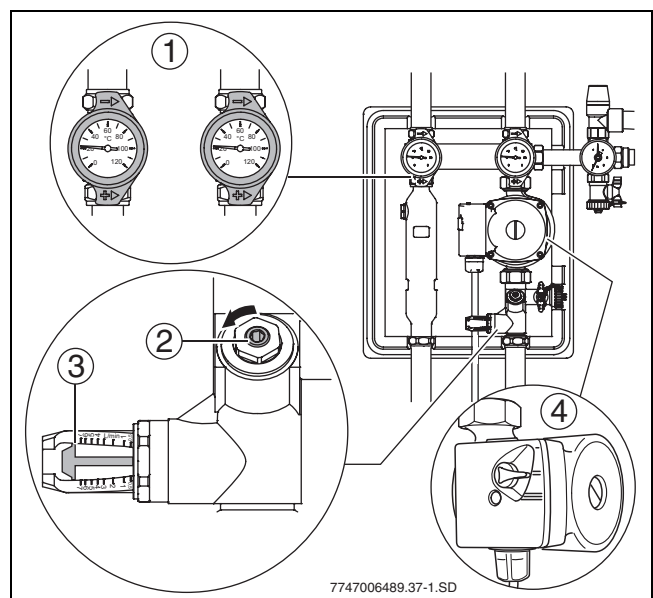

Fig. 20

- 1 Gravity brake ready for operation
 - 2 Adjusting screw on the flow limiter
 - 3 Indication point for the flow rate
 - 4 Pump switch on the solar pump
- ▶ For the required flow rate, see Tab. 7.



The values specified in Tab. 7 apply to single-row collector arrays or multi-row arrays connected in parallel. Collector arrays connected in series must be set using the total volumetric flow rate, which must be calculated.

- ▶ Check the flow rate in the inspection window of the flow limiter (→ Fig. 20, (3)).
- ▶ To pre-set the flow rate: adjust the solar pump's speed level switch (→ Fig. 20, (4)) so that the required flow rate is reached with as low a speed level as possible.



If the pre-set flow rate is not reached at the pump's highest speed level:

- ▶ Check maximum permitted pipe lengths and sizing (→ section 4.1).
- ▶ If necessary, install a stronger pump.

Flow rate l/min (at 30 - 40 °C in return)	
No. of collectors (volumetric flow rate l/h)	l/min
1 (50)	1
2 (100)	1.5 - 2
3 (150)	2.5 - 3
4 (200)	3 - 4
5 (250)	4 - 5
6 (300)	5 - 6
7 (350)	5.5 - 7
8 (400)	7 - 8
9 (450)	7.5 - 9
10 (500)	8 - 10

Tab. 8 Overview of flow rates

SPEED-CONTROLLED SOLAR PUMP

- ▶ Select the operating mode “Auto” on the controller. The flow rate will be regulated by means of the solar pump speed, based on current operating requirements.

AFTER COMMISSIONING

The viscosity of the heat transfer fluid makes air bubbles substantially more resilient than those in pure water.

- ▶ After several hours of solar pump operation, vent the solar heating system via the de-airator in the solar heating station and (if installed) the air vent on the roof.

7 COMMISSIONING, INSPECTION AND MAINTENANCE REPORT

We recommend conducting the first inspection and maintenance after about 500 operating hours, and then at intervals of 2 – 3 years.

► Fill out the report and tick off the tasks performed.

Owner:	Site location:
--------	----------------

Tab. 9

Commissioning, inspection and maintenance tasks		Page	Commis- sioning	Inspection/maintenance		
				1.	2.	3.
Date:						
General commissioning						
1.	Flow and return pipes connected and earthed?	9	<input type="checkbox"/>	-	-	-
2.	Pressure test carried out?	17, 15	<input type="checkbox"/>	-	-	-
3.	Air vent closed?	16	<input type="checkbox"/>	-	-	-
4.	Inlet pressure of the expansion vessel checked?	12	_____ bar	-	-	-
5.	Solar system verified to be free of air?	18	<input type="checkbox"/>	-	-	-
6.	pH value of heat transfer fluid checked? Replace heat transfer fluid if value is ≤ 7 (heat transfer fluid coloured brown, strong odour). ¹⁾		-	<input type="checkbox"/>	<input type="checkbox"/>	<input type="checkbox"/>
7.	Frost protection to _____ °C checked and analysed?	17	_____ °C	_____ °C	_____ °C	_____ °C
	Frost protection ensured until _____ (month/year) (please check frost protection every two years!)					
Solar heating circuit						
1.	Measure operating pressure when system is cold, and enter the result here. System temperature on blue thermometer?	17, 16	_____ bar _____ °C	_____ bar _____ °C	_____ bar _____ °C	_____ bar _____ °C
2.	Volumetric flow rate checked when the system is cold and result entered here?	17	__ l/min	__ l/min	__ l/min	__ l/min
	Solar pump setting (1/2/3)?					
3.	Gravity brakes ready to operate (closed)?	17	<input type="checkbox"/>	<input type="checkbox"/>	<input type="checkbox"/>	<input type="checkbox"/>
4.	Thermostatic DHW blending valve functioning correctly (if installed)?		<input type="checkbox"/>	<input type="checkbox"/>	<input type="checkbox"/>	<input type="checkbox"/>
Collector array						
1.	Visual inspection of collectors carried out?	2)	<input type="checkbox"/>	<input type="checkbox"/> ³⁾	<input type="checkbox"/> ³⁾	<input type="checkbox"/> ³⁾
2.	Collector temperature sensor correctly positioned and pushed into the sensor well until it bottoms out, and secured with screw fitting?		<input type="checkbox"/>	<input type="checkbox"/> ³⁾	<input type="checkbox"/> ³⁾	<input type="checkbox"/> ³⁾
3.	Visual inspection of the mounting structure carried out?		<input type="checkbox"/>	<input type="checkbox"/> ³⁾	<input type="checkbox"/> ³⁾	<input type="checkbox"/> ³⁾
4.	Visual inspection for leaks carried out at points where mounting structure meets roofing?		<input type="checkbox"/>	<input type="checkbox"/> ³⁾	<input type="checkbox"/> ³⁾	<input type="checkbox"/> ³⁾
5.	Visual inspection of pipe insulation carried out?		<input type="checkbox"/>	<input type="checkbox"/> ³⁾	<input type="checkbox"/> ³⁾	<input type="checkbox"/> ³⁾
6.	Flushing of collectors carried out (when needed) without cleaning additives?		<input type="checkbox"/> ³⁾	<input type="checkbox"/> ³⁾	<input type="checkbox"/> ³⁾	<input type="checkbox"/> ³⁾
Solar storage tank						
1.	Maintenance on solar cylinder carried out?	2)	-	<input type="checkbox"/>	<input type="checkbox"/>	<input type="checkbox"/>

Tab. 10

COMMISSIONING, INSPECTION AND MAINTENANCE REPORT

Commissioning, inspection and maintenance tasks		Page	Commis- sioning	Inspection/maintenance		
				1.	2.	3.
Control						
1.	Operating hours of solar pump P1: Period from _____ to _____ / ____ h	2)	__ - __ ____ h	__ - __ ____ h	__ - __ ____ h	__ - __ ____ h
	Operating hours of solar pump P2: Period from _____ to _____ / ____ h (a system will run for about 1200-2500 hours each year) ⁴⁾		__ - __ ____ h	__ - __ ____ h	__ - __ ____ h	__ - __ ____ h
2.	Pump functioning checked in the positions (On/Off/Auto)?		<input type="checkbox"/>	<input type="checkbox"/>	<input type="checkbox"/>	<input type="checkbox"/>
3.	Activation/deactivation temperature difference of solar pump ΔT pump 1 checked and entered here?		__ K/__ K	__ K/__ K	__ K/__ K	__ K/__ K
	Activation/deactivation temperature difference of solar pump ΔT pump 2 checked and entered here?		__ K/__ K	__ K/__ K	__ K/__ K	__ K/__ K
4.	Temperature indicated by all temperature sensors (resistances checked)?		<input type="checkbox"/>	<input type="checkbox"/>	<input type="checkbox"/>	<input type="checkbox"/>
5.	Temperature sensors correctly positioned, insulated and connected?		<input type="checkbox"/>	<input type="checkbox"/>	<input type="checkbox"/>	<input type="checkbox"/>
6.	Maximum tank temperature Tmax for solar cylinder 1 checked and entered here?		____ °C	____ °C	____ °C	____ °C
	Maximum tank temperature Tmax for solar cylinder 2 checked and entered here?		____ °C	____ °C	____ °C	____ °C
7.	Backup heating is functioning properly?		<input type="checkbox"/>	<input type="checkbox"/>	<input type="checkbox"/>	<input type="checkbox"/>
8.	Is the required set temperature (backup heating) being maintained by the controller?	<input type="checkbox"/>	<input type="checkbox"/>	<input type="checkbox"/>	<input type="checkbox"/>	
Comments						
	The solar heating system has been installed and put into operation, or inspected and serviced, as instructed in this instruction manual.	<input type="checkbox"/>	<input type="checkbox"/>	<input type="checkbox"/>	<input type="checkbox"/>	
	Company stamp / date / signature					

Tab. 10

- 1) Litmus paper for testing pH available from chemists or in maintenance kit.
- 2) See instruction manual for the component.
- 3) When needed.
- 4) Depends on specific system data.

8 FAULT FINDING

Information regarding faults can also be found in the installation instructions for the controllers.

Type of fault		
Effect	Possible causes	Remedy
Pump not running although activation conditions are met.		
The solar storage tank is not being supplied by the solar heating system.	Pump is faulty.	Check the pump and replace if necessary.
	The pump is stalled due to a mechanical blockage.	Unscrew and remove the slotted screw on the pump head and use a screwdriver to release the pump shaft. Do NOT strike the pump shaft with the screwdriver.
	Pump is not responding to the controller.	See controller instruction manual.
Pump continually switching on and off.		
Solar yield too low.	Not enough difference between activation and deactivation temperatures on the controller.	Check controller settings.
	Volumetric flow rate too high.	Check and adjust the flow rate.
	Temperature sensor position or contact is not correct.	Check temperature sensor position.
Pump does not switch off.		
Heat is being transferred out of the storage tank.	Temperature sensor faulty or in wrong position.	Check temperature sensor position, mounting and characteristics.
	Controller faulty.	Note: speed-controlled pumps do not switch off immediately, but only once the lowest speed is reached.
Domestic hot water is too hot.		
Risk of scalding	Storage tank temperature limit and blending valve are set too high.	Set the storage tank temperature limit and blending valve to a lower setting.
Domestic hot water too cold (or volume of domestic hot water is too low).		
	Domestic hot water thermostat on heating appliance, on heating controller or on blending valve is set too low.	Set the temperature as instructed in the applicable operating manual (max. 60 °C). Check that backup heating is functioning properly.

Tab. 11

Type of fault		
Effect	Possible causes	Remedy
Temperature differences in solar heating circuit are too high / flow temperature is too high / high collector temperature reached too quickly		
Solar yield too low or system damage.	Faulty temperature sensor or controller malfunction.	Check temperature sensor and settings of controller.
	Air in the system.	Bleed or purge the system.
	Volumetric flow rate too low.	Check/adjust the flow rate.
	Blocked line.	Check/purge the pipelines.
	Collector arrays not hydraulically balanced.	Carry out hydraulic balancing.
Pressure drop in the system.		
Solar yield too low.	Loss of heat transfer fluid at joints.	Braze any leaks. Replace seals. Retighten screw fittings.
	Loss of heat transfer fluid through an open safety valve.	Check inlet pressure and size of expansion vessel.
	Vapour has escaped through open air vent (normal operating function).	Close air vent after venting.
	Frost damage.	Check frost protection.
No flow noticeable on flow rate indicator despite pump running.		
Solar yield too low.	Shut-off fittings are closed.	Open shut-off fittings.
	Air in the system.	Bleed or purge the system.
	Indicator element in the flow limiter is sticking.	Clean the flow limiter.
Noises in the collector array at high levels of solar irradiation (vapour knocking).		
Leakages in solar heating circuit.	Balanced flow through the collector arrays is not possible.	Check piping.
	Expansion vessel too small or faulty.	Check design and inlet pressure of the expansion vessel and check operating pressure.
	Pump power is too low.	Check pump, replace if necessary.
	The collector with the collector temperature sensor is under shade.	Remove shade.
	Air in the system.	Bleed or purge the system and check slope of pipes.

Tab. 11

Type of fault		
Effect	Possible causes	Remedy
Solar cylinder is cooling rapidly.		
High heat loss.	Tank insulation is faulty or not correctly fitted.	Check insulation. Insulate the cylinder connection points.
	Controller setting for backup heating is not correct.	Check settings of boiler controller.
	Single-pipe circulation (micro-circulation in the pipelines).	Instal a "U" bend in the pipe to prevent heat convection.
	Gravity circulation via collector array or DHW recirculation line or backup heating.	Check gravity brakes.
	Hot water recirculation running too frequently and/or at night.	Check programmed on/off times and cyclic mode.
When sun is shining on collectors, the collector glass is fogged for a long period of time.		
Condensation water in the collector.	Insufficient ventilation of the collector.	Clean ventilation openings.
System performance is falling.		
Solar yield too low.	Collectors are under shade.	Remove shade.
	Air in the system.	Bleed or purge the system.
	Pump is running at decreased power.	Check the pump.
	Heat exchanger dirty/calcified.	Wash/decalcify the heat exchanger.
	Collector glazing is very dirty.	Clean the collector glazing with a glass-cleaning agent (no acetone).
Backup heating is running despite good solar irradiation.		
Solar yield too low.	Storage cylinder temperature sensor for backup heating is faulty or incorrectly positioned.	Check storage cylinder temperature sensor position, mounting and characteristics.
	DHW recirculation is incorrectly connected or switched on for too long.	Check recirculation connection; if necessary, reduce switch-on time for recirculation.
	Backup heating temperature set too high.	Check settings.
	Air in the system.	Bleed or purge the system.
	Controller faulty.	Check controller, replace if necessary.

Tab. 11

SOLAR THERMAL COMMISSIONING CHECKLIST

This Commissioning Checklist is to be completed in full by the competent person who commissioned the Solar Thermal System and associated equipment as a means of demonstrating compliance with the appropriate Building Regulations and then handed to the customer to keep for future reference.

Failure to install and commission this equipment to the manufacturer's instructions may invalidate the warranty but does not affect statutory rights.

Customer Name	Telephone Number
Address	
Commissioned by (print name)	
Company Name	Telephone Number
Company Address	
Commissioning Date	

To be completed by the customer on receipt of a Building Regulations Compliance Certificate.

Building Regulations Notification Number (if applicable)

Confirmation that required areas of the installation have been notified to Local Authority Building Control (LABC)

a). Initials of commissioning engineer

b). Competent Persons Scheme (CPS) details or details of LABC direct notification

Confirmation that panels have been installed without lessening the structure, weathering and fire resistance of the roof in accordance with the relevant Building Regulations and standards. Initials of commissioning engineer

COLLECTOR DETAILS

Make of collector	Model of collector
Serial number of each collector: (if more than 6 collectors please append additional sheet)	
i.	ii.
iii.	iv.
v.	vi.

INSTALLATION DETAILS

Solar System Operating Pressure	<input type="text"/> bar (cold)	Expansion vessel air/nitrogen charge	<input type="text"/> bar (cold)
Expansion or drain back vessel size	<input type="text"/> litres		
Operating correctly: Yes <input type="checkbox"/>	Treated for leaks and flushed: Yes <input type="checkbox"/>	Filled and purged for air: Yes <input type="checkbox"/>	
System heat transfer fluid details:			
What type/make of heat transfer fluid used?	System volume <input type="text"/> litres		
What is the fluid mix: Water <input type="text"/> %	Glycol <input type="text"/> %		
Frost protection provided to <input type="text"/> °C			
Is the installation in a hard water area (above 200ppm)?	Yes <input type="checkbox"/>	No <input type="checkbox"/>	
If yes, has a water scale reducer been fitted or has Tmax been limited to 60°C?	Yes <input type="checkbox"/>	No <input type="checkbox"/>	
What type of scale reducer has been fitted?			
Air purged from solar primary circuit: Yes <input type="checkbox"/>	Primary circuit valves and air vent(s) set to final operating positions:	Yes <input type="checkbox"/>	
Pump speed setting recorded: Speed setting	Max flow rate <input type="text"/> litres/min		
Solar primary circuit pressure relief valves tested for correct operation:	Yes <input type="checkbox"/>	Location	
Device for limiting hot water temperature outlets has been fitted:	Yes <input type="checkbox"/>	No <input type="checkbox"/>	
Type	Location		
All exposed pipework lagged in accordance with regulations using suitably temperature rated materials	Yes <input type="checkbox"/>		
For unvented hot water storage cylinder, will controls stop solar fluid circulation in the event of cylinder overheating?	Yes <input type="checkbox"/>		

SOLAR SYSTEM CONTROLS

Make and model of DTC			
Temperature sensors checked and operating correctly	Yes <input type="checkbox"/>		
Differential Temperature Controller (DTC) settings:	T on <input type="text"/> °C	T off <input type="text"/> °C	
	T max <input type="text"/> °C	Other DTC Settings	
Thermostat located in back-up heating zone of cylinder	Yes <input type="checkbox"/>	No <input type="checkbox"/>	
Have optimum settings for HW controls been explained to the customer?	Yes <input type="checkbox"/>	No <input type="checkbox"/>	
Does this include Legionella Bacteria protection settings with back up heating system to bring boiler volume to 60°C for an hour once a day?	Yes <input type="checkbox"/>	No <input type="checkbox"/>	
Electrical installation is accordance with BS7671	Yes <input type="checkbox"/>		
Location of electrical isolation switch to solar control/pump unit			

ALL INSTALLATIONS

The heating and hot water system complies with the appropriate Building Regulations	Yes <input type="checkbox"/>
The system and associated products have been installed and commissioned in accordance with the manufacturer's instructions	Yes <input type="checkbox"/>
The efficient operation of system and its controls have been demonstrated to and understood by the customer	Yes <input type="checkbox"/>
The manufacturer's literature, including Benchmark Checklist and Service Record, has been explained and left with the customer	Yes <input type="checkbox"/>

Commissioning Engineer's Signature

Customer's Signature

To confirm satisfactory demonstration and receipt of manufacturer's literature)

* All installations in England and Wales must be notified to Local Authority Building Control (LABC) either directly or through a Competent Persons Scheme. A Building Regulations Compliance Certificate will then be issued to the customer.



Service Record

It is recommended that your heating system is serviced regularly and that the appropriate Service Record is completed.

Service Provider

Before completing the appropriate Service Record below, please ensure you have carried out the service as described in the manufacturer's instructions.

Always use the manufacturer's specified spare part when replacing controls.

Service 1 Date

Energy Efficiency Checklist completed? YES NO

Engineer Name _____

Company Name _____

Telephone Number _____

Comments _____

Signature _____

Service 2 Date

Energy Efficiency Checklist completed? YES NO

Engineer Name _____

Company Name _____

Telephone Number _____

Comments _____

Signature _____

Service 3 Date

Energy Efficiency Checklist completed? YES NO

Engineer Name _____

Company Name _____

Telephone Number _____

Comments _____

Signature _____

Service 4 Date

Energy Efficiency Checklist completed? YES NO

Engineer Name _____

Company Name _____

Telephone Number _____

Comments _____

Signature _____

Service 5 Date

Energy Efficiency Checklist completed? YES NO

Engineer Name _____

Company Name _____

Telephone Number _____

Comments _____

Signature _____

Service 6 Date

Energy Efficiency Checklist completed? YES NO

Engineer Name _____

Company Name _____

Telephone Number _____

Comments _____

Signature _____

Service 7 Date

Energy Efficiency Checklist completed? YES NO

Engineer Name _____

Company Name _____

Telephone Number _____

Comments _____

Signature _____

Service 8 Date

Energy Efficiency Checklist completed? YES NO

Engineer Name _____

Company Name _____

Telephone Number _____

Comments _____

Signature _____

Service 9 Date

Energy Efficiency Checklist completed? YES NO

Engineer Name _____

Company Name _____

Telephone Number _____

Comments _____

Signature _____

Service 10 Date

Energy Efficiency Checklist completed? YES NO

Engineer Name _____

Company Name _____

Telephone Number _____

Comments _____

Signature _____

WORCESTER, BOSCH GROUP:

TECHNICAL SUPPORT: 0844 892 4010

APPOINTMENTS: 0844 892 3000

SPARES: 01905 752576

LITERATURE: 0844 892 9800

TRAINING: 01905 752526

SALES: 01905 752640

WEBSITE: worcester-bosch.co.uk

Worcester, Bosch Group
Cotswold Way, Warndon, Worcester WR4 9SW.
Tel. 0844 892 9900

Worcester, Bosch Group is a brand name of Bosch Thermotechnology Ltd.
worcester-bosch.co.uk

6 720 643 603 (2011/11)



WORCESTER
Bosch Group